

# SCP500/800

Operating Manual  
Technical Description  
Installation Instruction

# SCP500/800

## Operating Manual Technical Description Installation Instruction

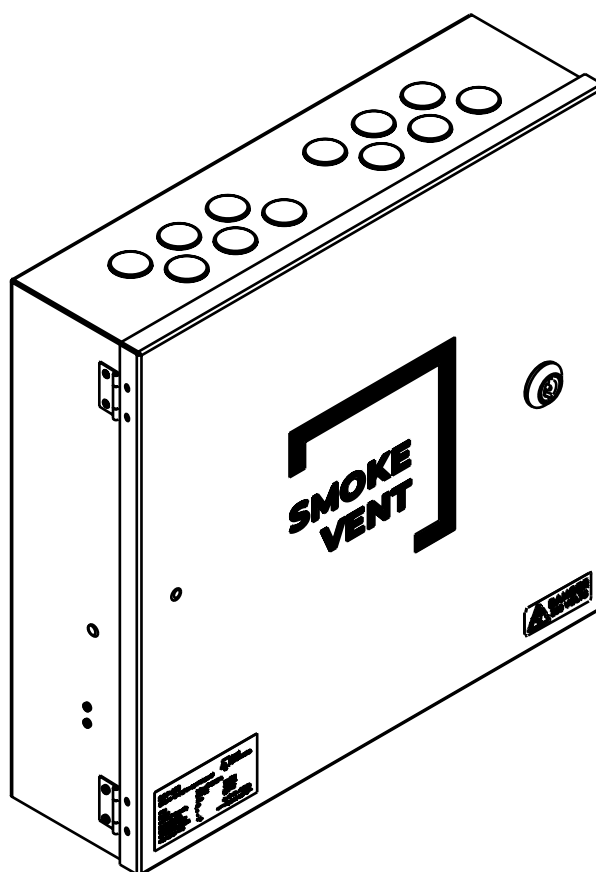

Version 1.1.01

# SCP500/800

Operating Manual  
Technical Description  
Installation Instruction

## Table of Contents

05	Safety information
06	Technical specifications
07	Accessories
08	Dimensions
09	Overview of controller connectors
10	Overview of controller onboard items
11	Functional description
12	System parameters
14	Status LED descriptions
15	Installation
16	Connections
26	Networking
28	System types
40	Troubleshooting
41	Commissioning
42	Log book
43	Support



## UKCA Declaration of Conformity

Doc. No. T042  
Company Teal Products Limited  
Address 8a Orchard Industrial Estate  
Toddington  
Cheltenham  
GL54 5EB, UK  
Telephone +44 (0)1242 620318  
Email sales@tealproducts.co.uk

**We declare that the following product:**

Product Smoke control unit  
Models SCP-500  
SCP-800

**Is in conformity with the essential requirements and other relevant requirements of:**

EMC Directive 2014/30/EU  
Low voltage directive (LVD) 2014/35/EU  
RoHS Directive 2011/65/EU  
The Electromagnetic Compatibility Regulations 2016

**Designated standards:**

EN 50130-4:2011+A1:2014	BS EN 55032:2015+A11:2020
BS EN IEC 61000-6-3:2021	BS EN IEC 61000-6-4:2019
BS EN 61000-4-2:2009	BS EN 61000-4-8:2010
BS EN IEC 61000-4-3:2020	BS EN 61000-4-6:2014

Sam Yiend  
Managing Director  
Cheltenham, 07/07/2023

Unit 8A  
Orchard Industrial Estate  
Toddington  
Cheltenham  
GL54 5EB

01242 620318  
sales@tealproducts.co.uk  
tealproducts.co.uk

## 01. Safety Information

Installation should be carried out only by suitably competent persons.

Danger of entrapment may be present when the connected AOV is accessible. Suitable safety procedures should be considered when installing and testing the system.

The system should be installed only according to the details provided in these instructions. Variations may prevent the system operating as designed and are not guaranteed.

The manufacturer does not assume any liability for any injury or damage from inappropriate usage or incorrect installation.

### Caution 230v mains voltage

Can cause injury or death. Ensure mains is isolated before carrying out installation works or making any changes.

Adhere to current regulations for cable routing of extra low voltage cables and mains cables. Use correct cable types for the intended application.

Motor cables should be sized to meet the requirement of the maximum absorbed current of the total number of connected motors on each cable.

The SCP500/800 is for use exclusively for the operation open and close of 24v DC AOVs for smoke ventilation / extraction (and environmental control) which fall within the maximum output of the motor output.

The system should be integrated into a cause and effect to suit the end application. Configuration of the SCP500/800 can be set using the DIP switches to meet the requirements of the cause and effect.

### Maintenance

The SCP500/800 control panel is used in smoke control systems and must be checked by a competent person, serviced and if required, repaired as necessary as part of a scheduled maintenance plan.

Service periods for suitably trained smoke control technicians are indicated on the remote call points (if enabled) 12 months from initial power up, or subsequent 12 month period after last service timer reset. This is identified by a flashing yellow fault indicator and solid green OK indicator being simultaneously displayed on remote call points.

The smoke control system should also be regularly tested for correct operation. Batteries should be replaced after 4 years maximum. Batteries should be disposed of responsibly.

## 02. Technical Specifications:

Mains supply input	230v AC (+/- 10%) 50/60Hz
Supply requirement	2A 230v AC
Inrush current	40A 230v AC
Motor Output	Rated output voltage 24v DC +20%/- 25% Open circuit voltage 28v Ripple 200mVp-p Maximum output current 5A (SCP500) and 8A (SCP800)
Secondary supply	2x12v 7Ah connected in series Only use genuine Yuasa NP7-12 batteries
Charging	Charge voltage 27.6v @ 20°C Charge current 500mA max
Operating duration on secondary supply	72h from fully charged
Environmental	-5 to +40°C 90% RH max
Protection class	IP30
Switch on duration	40% ED
Maximum load on back-up supply (no mains)	50mA
Interruption time between power supply change-over	<1s
Cable monitoring	Motor output 2x10k resistor Smoke detector 10k resistor 6-wire call point line (fire button signal) 10k resistor
Cable terminations	Screw terminals 0.3 – 3.3mm <sup>2</sup> CSA (22-12 AWG)
Indication	Local indication of; System healthy (ok) Alarm (fire) Rain Motor output active Smoke detector error Call point error Motor output error Network error Overload (call point, smoke detector, comfort & aux 24v) PSU error Battery Error  Remote indication (on compatible call point) of; System health (ok & Fault) Alarm (fire)
Auxiliary output	24v DC +20%/- 25% 100mA max
Cabinet	365mm (w) x 353mm (h) x 103mm (d)
Network	Up to 31 panels in a stand-alone networked system Optional Modbus controlled mode

## 03. Accessories

Code	Description
BG1/S/O	Break Glass Call Point Orange
BG3/FOS/O	Manual Call Point Orange 3-Wire
BG6/FOS/O	Manual Key Switch Orange
HMI-SCP	Touchscreen User Interface
S50-1	Rocker Switch 1-Gang White
SCP-101-01	Replacement Batteries (2x) For SCP500/800
SCP-102-01	Replacement Key For SCP500/800
SCP-103-01	Replacement Transformer For SCP500
SCP-104-01	Replacement Transformer For SCP800
SCP-105-01	Replacement PCB Only For SCP500/800
SCP-106-01	Motor End Of Line Module
SCP-107-01	Smoke Sensor End Of line Resistor (10x)
SCP-109-01	Replacement Enclosure For SCP500/800
SCP-116-01	Fire Alarm Input Module
SSR3	Optical Smoke Sensor & Base
TM1	Digital Timer
TS1	Room Thermostat
TS1-TP	Room Thermostat - Tamper Proof
WLA330	Wind & Rain Sensor
WLA331	Rain Sensor
WSK320	Manual Call Point Orange 6-Wire
WSCMIP	Mini Indicator Panel

## 04. Dimensions

All dimensions in mm.

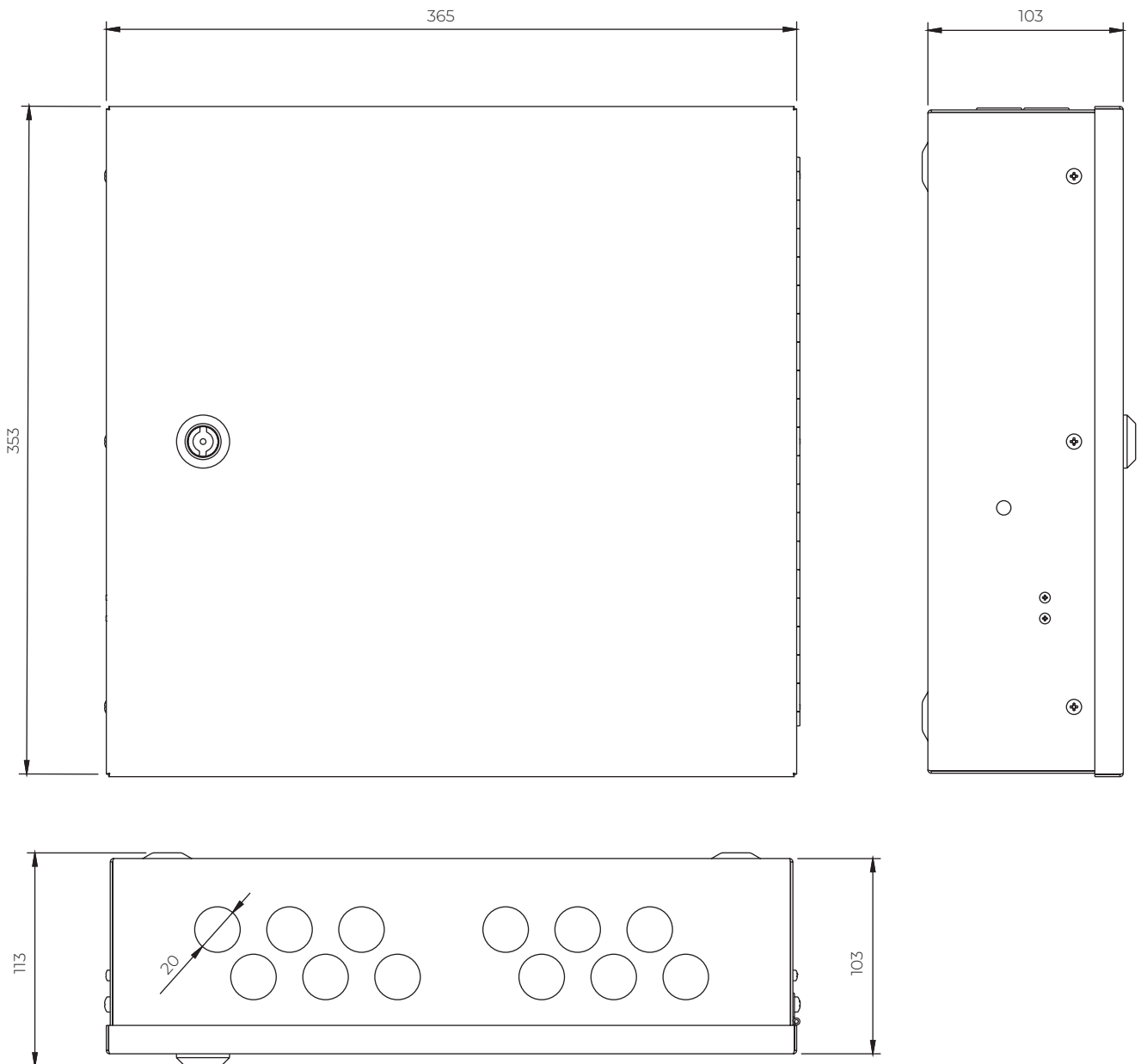

# 05. Overview of SCP500/800 inputs and outputs

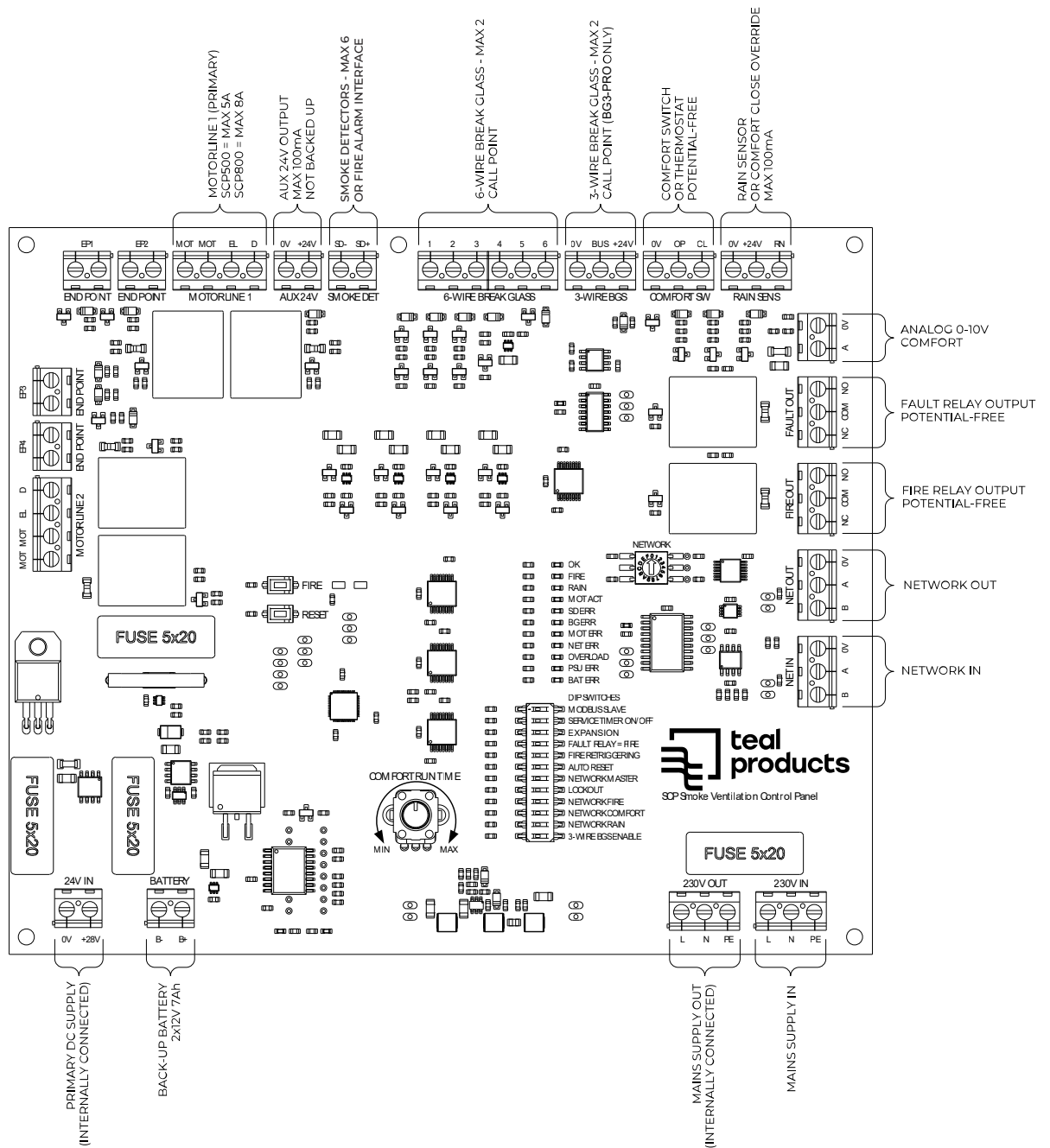

## 06. Overview of SCP500/800 onboard items

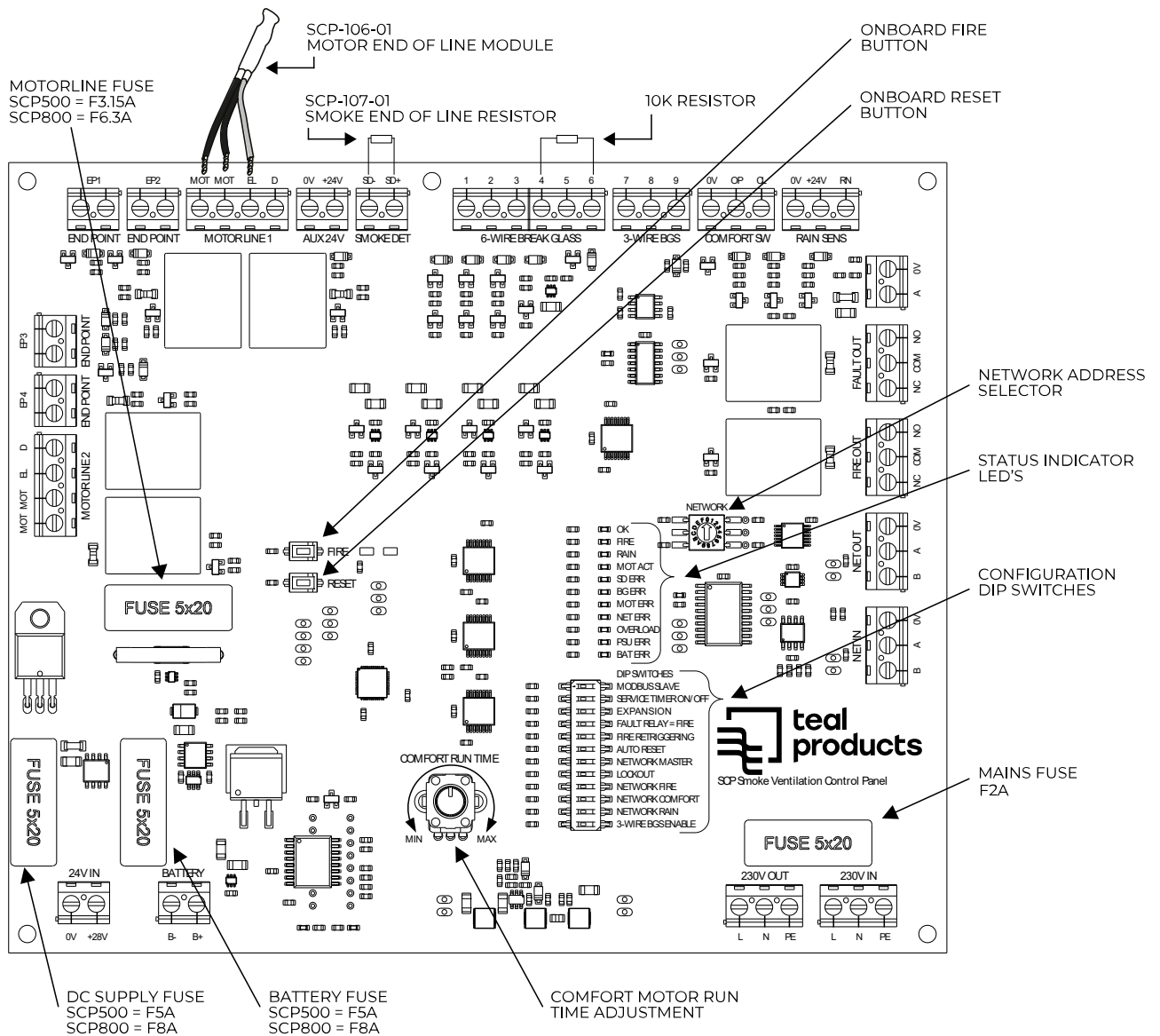

## 07. Functional Description

The SCP500/800 smoke ventilation control panel (system) is used for operating smoke vents (AOVs) which are designed to operate from a 24v DC supply.

### Smoke Control

Activating the system into fire can be achieved by any of the following conditions;

- Pushing the onboard fire button
- Manual activation from attached call point(s)
- Smoke detection from attached smoke detector(s)
- Potential-free input from remote fire alarm controls
- Network activation (DIP switch setting required)

After the system has entered fire, the connected AOV will be powered into the open position.

Clearing fire conditions (reset);

- Pushing the onboard reset button
- Reset from attached call point(s)
- Automatically after fire alarm is reset (DIP switch setting required)
- Network reset (from call point on other networked control panel(s))

After the system has been reset, the connected AOV will be powered to the fully closed position.

Priority is given to alarm inputs (smoke detector / call point / fire alarm) so the system can only be reset when all alarm inputs are cleared. After reset, the system will re-enter fire condition if any alarm inputs remain active.

### Comfort Control

The system is capable of opening the connected AOV partly or fully based on inputs from either a manual switch (or thermostat for automatic control). Partial opening can be achieved by reducing the motor output timer using the comfort run time potentiometer.

If the AOV has the potential for rain ingress into the building, connection of a rain sensor is possible. The rain sensor will have priority over any comfort switches or thermostats when the rain sensor is active. If a thermostat is used, when the rain sensor has cleared, the AOV will re-open if the thermostat is active for cooling.

### Network Functionality

The control panel can be connected to other SCP control panels on a network to provide a solution to operate as a complete multiple zone smoke ventilation system. For example, using the DIP switch setting it is possible to control a smoke shaft ventilation system and coordinate the AOV operation to meet current standards and regulations, and operate to multiple cause and effect scenarios.

In addition to smoke ventilation, the system can open and close multiple AOVs for comfort cooling ventilation from thermostats and rain sensor(s) connected to SCP control panels on the network.

## 08. System Parameters

### Network Address Selector

When connecting multiple SCP500/800 control panels together to form a multi-zone network each control panel must be assigned a Network Address using the network address selector.

- SLAVE Panel: Assign SLAVE panels 1-30 in sequence without missing any numbers.
- MASTER Panel: There can be only 1 x MASTER panel per network - typically the stairwell or head of shaft panel. Assign the master panel to the number of slave panels i.e. 3 x slave panels, master set to 3 OR 9 x slave panels, master set to 9.

Expansion Dip Switch (3) OFF (Default):

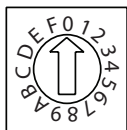

0 = OFF	4 = 4	8 = 8	C = 12
1 = 1	5 = 5	9 = 9	D = 13
2 = 2	6 = 6	A = 10	E = 14
3 = 3	7 = 7	B = 11	F = 15

Expansion Dip Switch (3) ON:

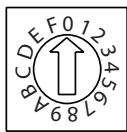

0 = OFF	4 = 19	8 = 23	C = 27
1 = 16	5 = 20	9 = 24	D = 28
2 = 17	6 = 21	A = 25	E = 29
3 = 18	7 = 22	B = 26	F = 30

### Comfort Run Time Adjustment

When control of the connected AOV requires to be used to control the temperature/air quality a manual switch or thermostat can be used to operate the AOV open/closed based on user inputs or automatically via a thermostat. If required, the amount of opening can be adjusted using the COMFORT RUN TIME potentiometer. This will adjust the amount of opening based on a time adjustment of 5-80s. If there is a power failure, the AOV will automatically close if it is in the open position.

COMFORT RUN TIME

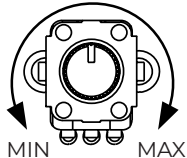





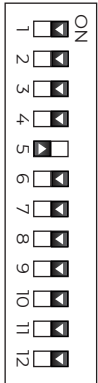





MIN = 5 seconds
25% = 20 seconds
50% = 40 seconds
75% = 60 seconds
MAX = 80 seconds

## Dip Switch Settings



Switch	Name	On Behaviour	Off Behaviour
1	Modbus Slave	Control panel fully controlled by network host device (Modbus version only).	Control panel under local control. (Default)
2	Service Timer On/Off	Service timer is reset and held. Toggle from Off to On and back to Off to start the service timer for another 12 month period.	Service timer is running. After a period of 12 months being powered up the yellow LED is lit on remote call points. (Default)
3	Expansion	Network address can be set to between 16-30.	Network address can be set to between 1-15. (Default)
4	Fault Relay = Fire	Fault relay operates as another fire output. NO and NC contacts act as normal.	Fault relay operates as a fault output (NC is a powered NO so connect between COM and NC if a normally open contact is required). (Default)
5	Fire Re-Triggering	Motor output re-activates every 2min for a period of 30mins. (Default)	Motor output operates once only.
6	Auto Reset	Control panel resets when input from fire alarm or interface is cleared of smoke.	Control panel latches in fire and can only be reset from reset buttons or network. (Default)
7	Network Master	Control panel is the master device on the network.	Control panel is either stand-alone or a network node. (Default).
8	Lockout	Control panel cannot enter fire conditions from connected inputs if another device on the network is in fire.	Control panel can enter fire condition from connected inputs at any time. (Default)
9	Network Fire	Control panel enters fire condition if any other device on the network is in fire. Lockout of this control panel is not available with this setting On.	Control panel does not enter fire condition when any other device on the network is in fire. (Default)
10	Network Comfort	Control panel opens the connected AOV when any other device on the network is open on comfort.	Control panel does not respond to comfort signals from other devices on the network. (Default)
11	Network Rain	Control panel closes the connected AOV if it is open in comfort when another device on the network has a rain signal.	Control panel does not respond to rain signals from other devices on the network. (Default)
12	3-Wire BGS Enable	3-Wire call point interface is enabled.	3-Wire call point interface is disabled. (Default)

## 09. Status LED Descriptions

 OK
 FIRE
 RAIN
 MOT ACT
 SD ERR
 BG ERR
 MOT ERR
 NET ERR
 OVERLOAD
 PSU ERR
 BAT ERR

LED Name	Function when illuminated
OK	Control panel is healthy and operating normally.
FIRE	Steady: Control panel is in fire condition. Flashing: Control panel is locked out and cannot enter fire condition.
RAIN	Rain input is active, or network rain is active.
MOT ACT	Motor output is active (24v output is switched on).
SD ERR	Fault on the smoke detector input. Smoke detector is removed, 10k end of line is missing, or open circuit. If short circuit the OVERLOAD LED will also be illuminated.
BG ERR	Fault on the call point inputs. Either a call point is removed or 10k resistor is missing from 6-wire break glass connections 4 and 5. Check for cable faults, loose or incorrect termination.
MOT ERR	Fault on the motor output. Either the end of line module is missing or there is a cable fault, or the motor fuse is blown.
NET ERR	Steady = Network fault on this panel (config or cable) Flashing = Fault on another panel elsewhere on the network
OVERLOAD	Too much current is being used by either the AUX 24 output, rain sensor 24v, smoke detector, 3-wire call point 24v output or terminals 1, 2 or 3 of the 6-wire call point terminals. Note: after any OVERLOAD fault, the onboard reset button needs to be pressed when the cause of the overload has been rectified to restore power to the affected output.
PSU ERR	Mains is disconnected or low voltage, or 28v fuse is blown.

## 10. Installation

The SCP500/800 must be surface mounted in a dry environment. The SCP500/800 is only suitable for indoor mounting.

With the batteries removed, fasten the cabinet to a solid flat wall ensuring a good fixing is achieved. Fasten using suitable fixings for the wall construction through the 4 x 6mm mounting holes as shown below;

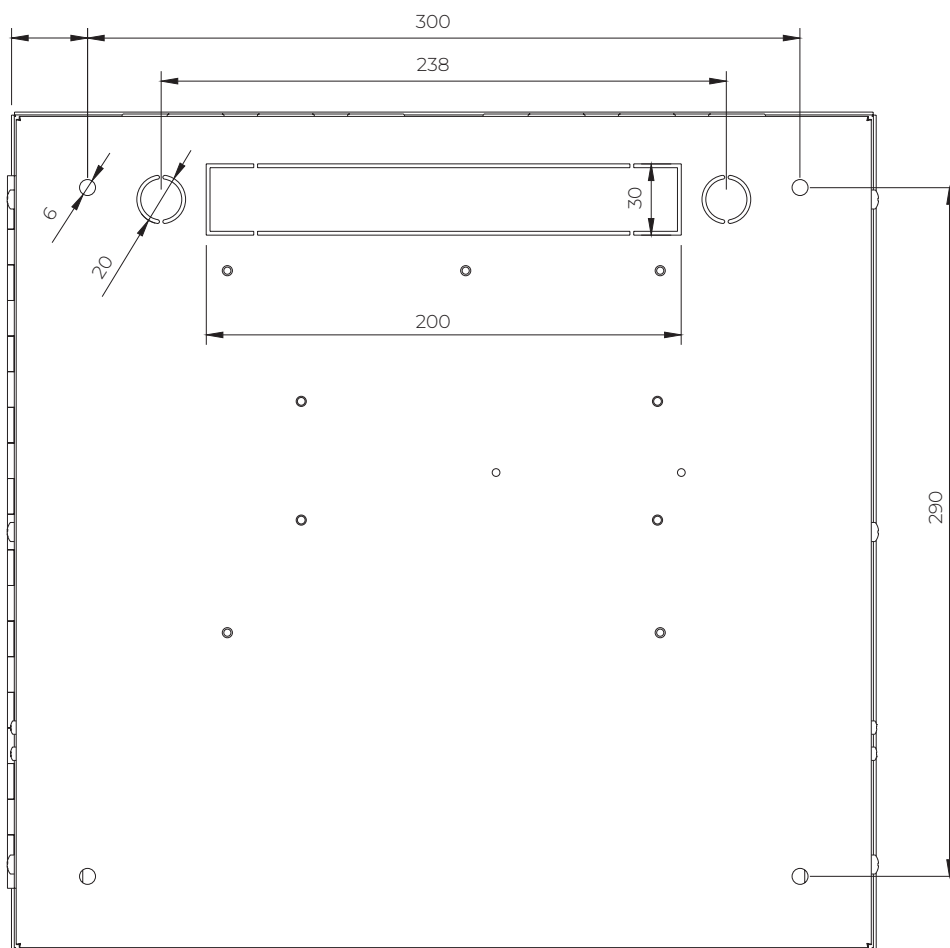

### Cable Entry

Top entry using the 12 x 20mm glands. Use 20mm grommets (not supplied) or 20mm glands (not supplied) for each cable.

Rear entry using the 200x30mm knock-out plate located on the rear. Separate 20mm rear entry holes are provided for mains entry. When using rear entry ensure grommet strip (not supplied) is used for the 200x30mm knock-out, and 20mm grommets (not supplied) for the mains entry holes.

## 11. Connections

### Wiring Schematic

The below diagram is a basic guide cable cores. Please refer to national regulations for correct specifications, alternatively please contact our technical team who will be happy to help.

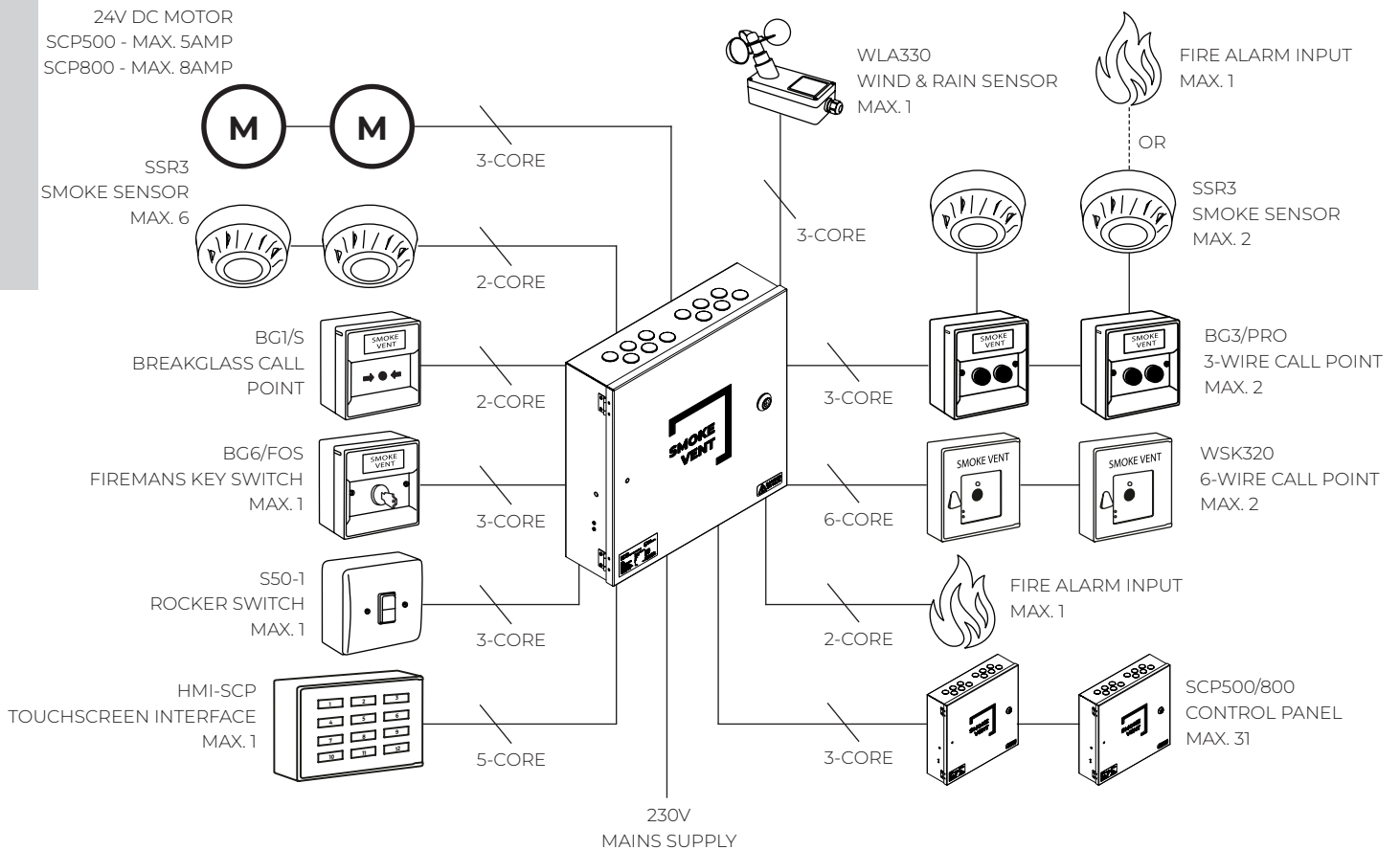

### Motor Cable Sizes

Recommended cable sizes from control panel to motor(s) depending on total motor consumption.

Motor Current	3-Wire 0.75mm <sup>2</sup>	3-Wire 1.5mm <sup>2</sup>	5-Wire 1.5mm <sup>2</sup>	3-Wire 2.5mm <sup>2</sup>	5-Wire 2.5mm <sup>2</sup>	3-Wire 4mm <sup>2</sup>
1A	42m	84m	168m	140m	280m	224m
2A	21m	42m	84m	70m	140m	112m
5A	8m	17m	34m	28m	56m	45m
8A	5m	11m	21m	18m	35m	28m

## 230V Mains Supply

Supply the panel from a 5A mains supply and connect to the 230V IN terminals. Ensure the mains supply is isolated before attempting any mains connections.

## Back-Up Battery

Connect 2x 12V 7Ah sealed lead acid batteries in series to the battery connections. **Observe the correct polarity before connecting.**

- B+ should be connected to the **RED** terminal of one of the batteries.
- B- should be connected to the **BLACK** terminal of the other battery.
- Link the two batteries together using the supplied link cable to the remaining **RED** and **BLACK** terminals.

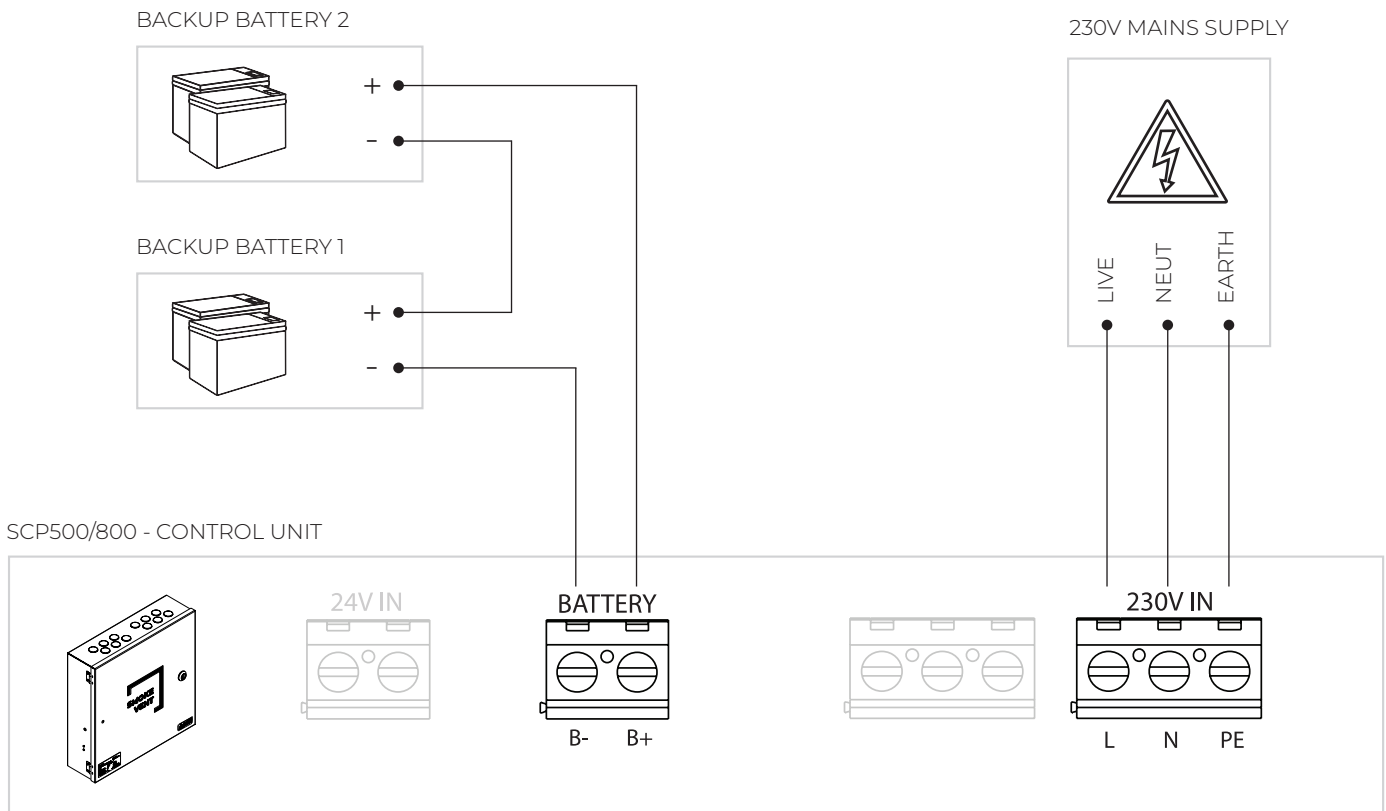

## Basic Connections

 Must be placed in the last motor junction box for cable monitoring.

 Must be placed in the last smoke sensor for cable monitoring.

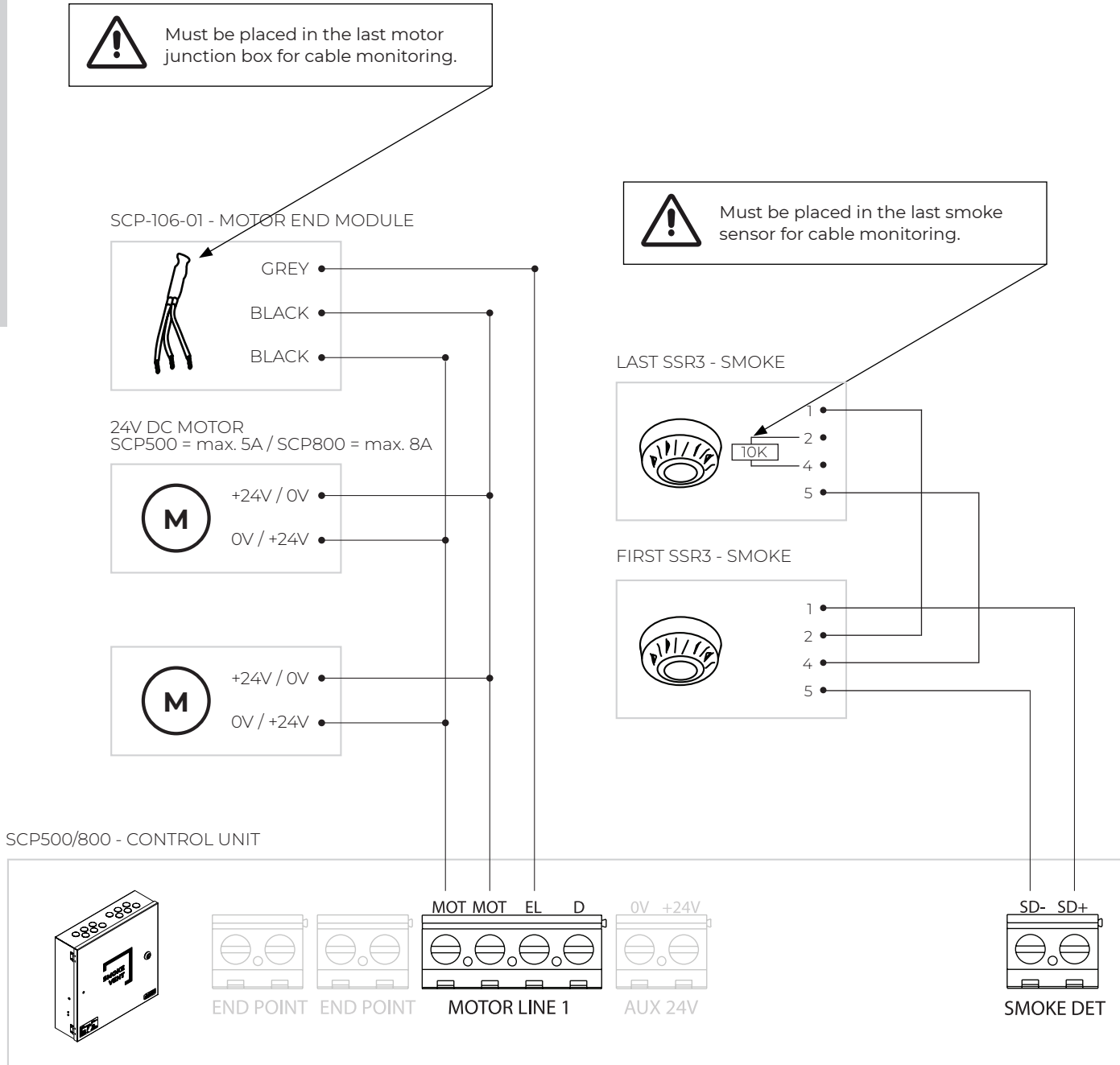

## BG3-PRO - Pairing Mode (max. 2)

- Connect the BG3-PRO firemans switches (max. 2) to the SCP500/800 control panel
- Set dip switch T2 to ON.
- Turns mains supply on and connect batteries.
- The BG3-PRO will beep and the LED's will start flashing to confirm pairing mode.
- Press the Reset button the BG3-PRO.
- The BG3-PRO will beep and the LED's will stop flashing to confirm pairing is complete.
- If two BG3-PRO are connected you must ensure the second Reset button is pressed within 5 minutes.



**HOW TO  
 Video Guide**

BG3-PRO - FIREMANS SWITCH  
 (max. 2)

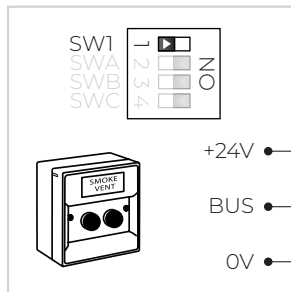

BG3-PRO - FIREMANS SWITCH  
 (max. 2)

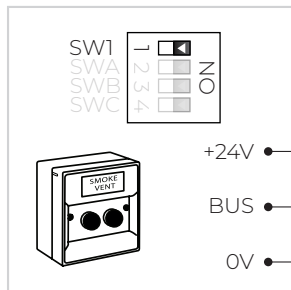

S50-1 - ROCKER SWITCH  
 (max. 1)

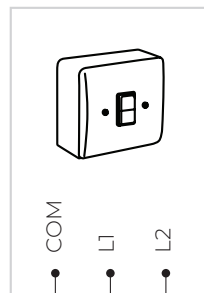

WLA 330 - WIND & RAIN SENSOR  
 (max. 1)

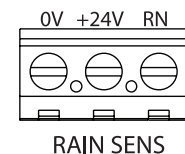
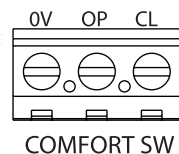
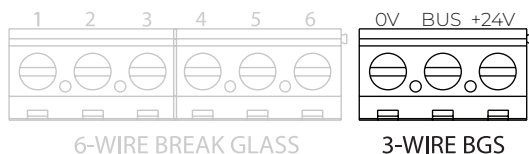
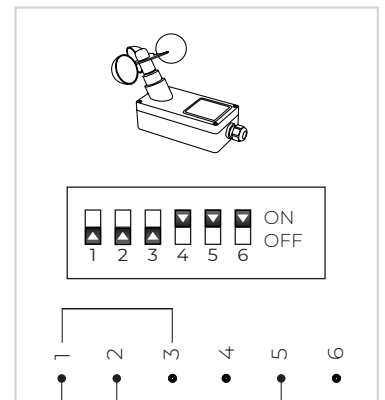

## Fire Alarm Interface

The SCP500/800 can be triggered by an external fire alarm system. A normally open potential-free contact is required for fire alarm interfacing. To connect an external fire alarm, use a SCP 116 module in-line with the fire alarm interface/relay. It is possible to auto-reset the SCP500/800 at the same time the fire alarm system clears the signal from the interface/relay by setting DIP switch 6 to ON.

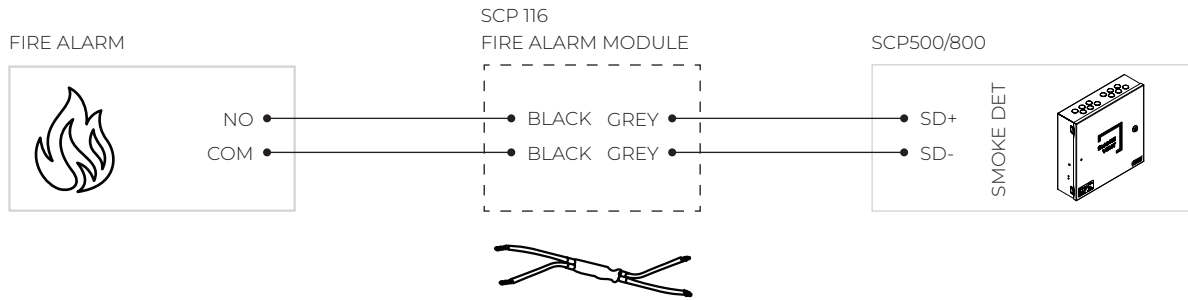

## Fire Alarm Interface & BG3/FOS Firemans Switch

A potential-free fire alarm interface can also be connected to the BG3-PRO call point. To connect an external fire alarm, use a SCP 116 module in-line with the fire alarm interface/relay. It is possible to auto-reset the SCP500/800 at the same time the fire alarm system clears the signal from the interface/relay by setting DIP switch 6 to ON.

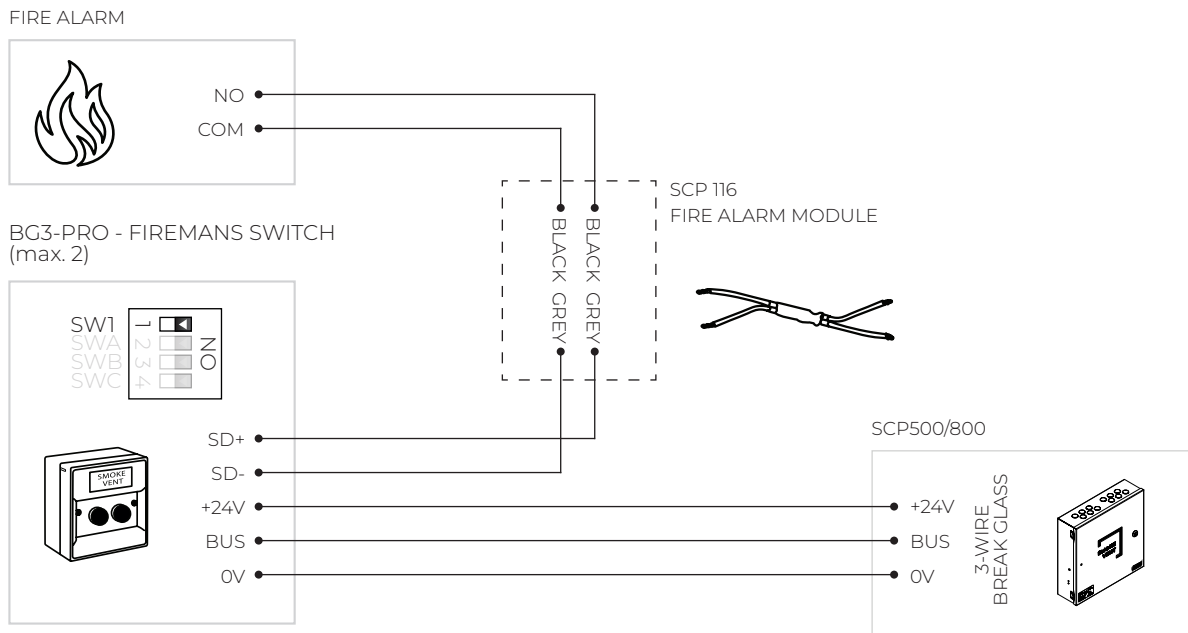

## Smoke Sensor(s)

It is possible to connect up to six smoke detectors via the BG3-PRO firemans switch. Connect conventional smoke detectors on a radial circuit from the 0v and SD+ terminals on the BG3-PRO. See below for linking multiple detectors.

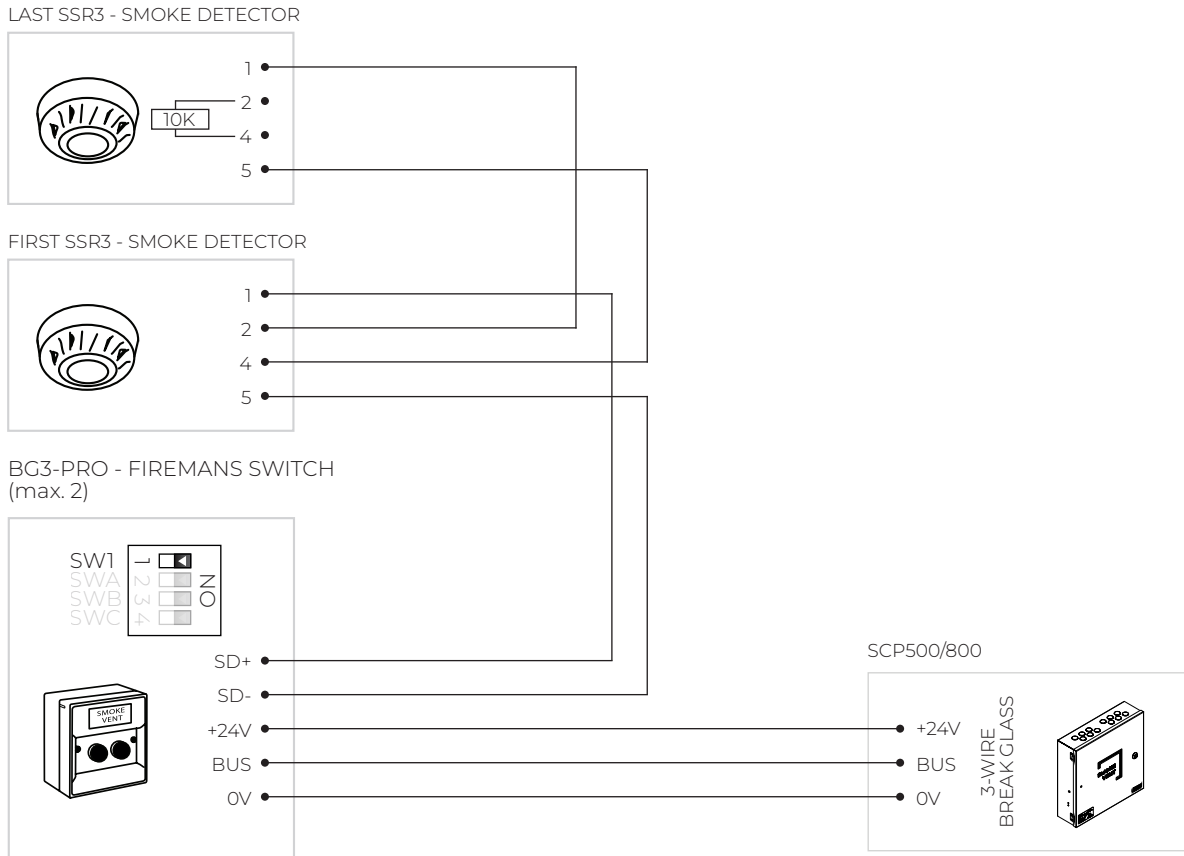

## BG1/S - Breakglass Call Point

BG1/S call points can be connected on a single radial circuit. Only 1 x BG1/S call point can be connected to the SCP500/800 control panel.

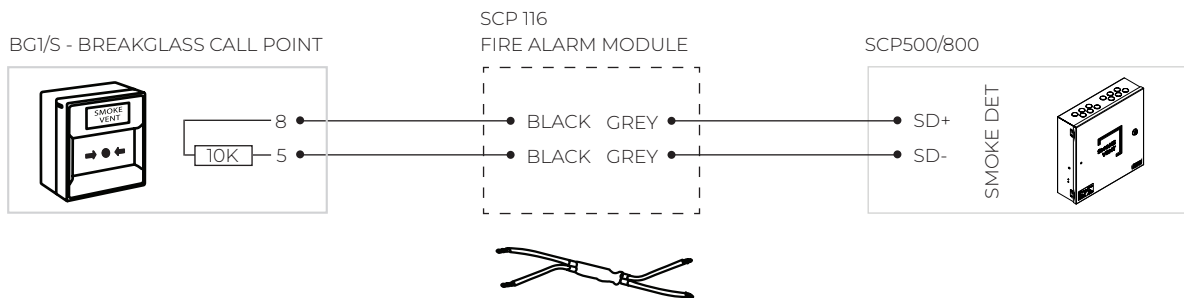

## WSK320 - Firemans Switch (6-Wire)

For a single 6-wire call point like the WSK320, connect as shown in the picture below. Remove the factory fitted 10k resistor from terminals 4 & 6. Ensure the 10k jumper is fitted in the call point to enable the 10k end of line resistor in circuit. For up to 2 x 6-wire call points, connect as shown below, and ensure the 10k jumper is fitted ONLY on the last call point.

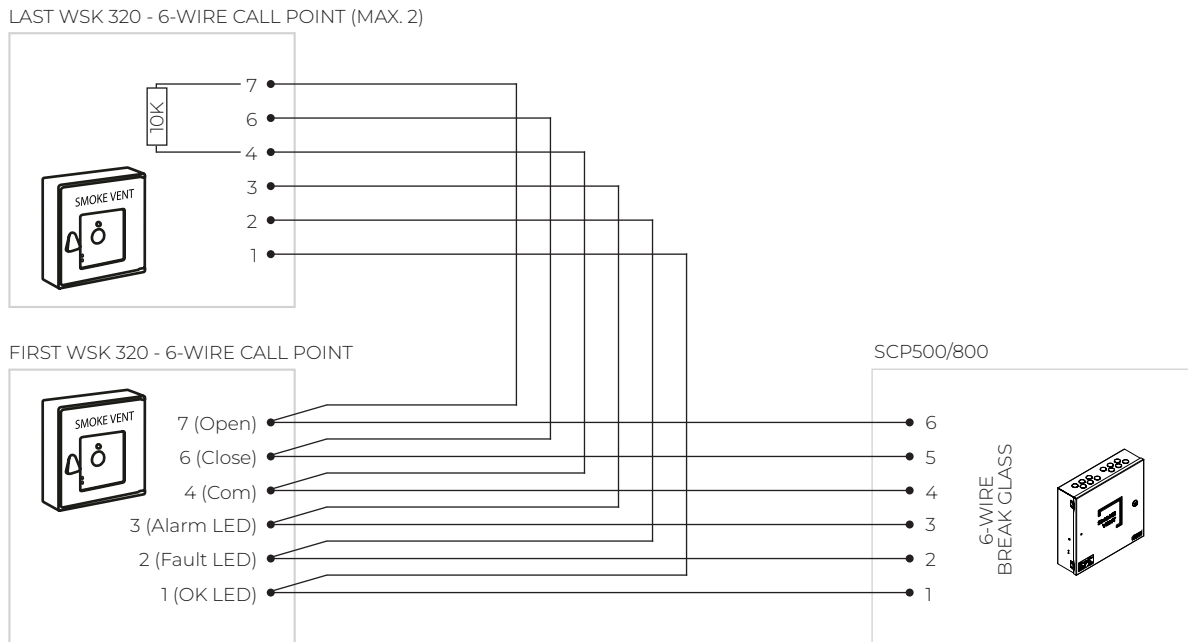

## BG6/FOS - Firemans Key-Switch

BG6/FOS firemans key-switches can be connected on a single radial circuit. Only 1 x BG6/FOS firemans key-switch can be connected to the SCP500/800 control panel.

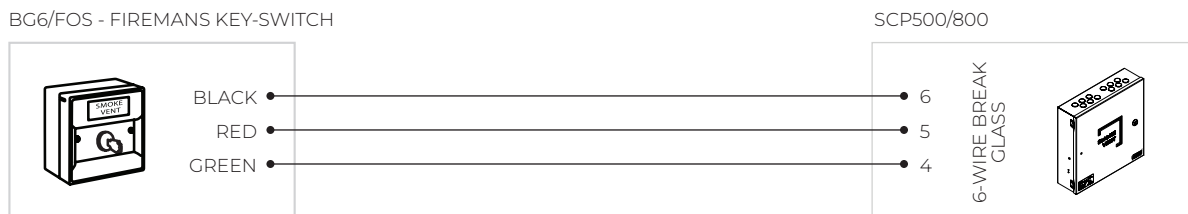

## Comfort Control Inputs

When control of the connected AOV requires to be used to control the temperature/air quality, a manual switch or thermostat can be used to operate the AOV open/closed based on user inputs or automatically via a thermostat. If required, the amount of opening can be adjusted using the COMFORT RUN TIME potentiometer. This will adjust the amount of opening based on a time adjustment of 5-80s. If there is a power failure, the AOV will automatically close if it is in the open position.

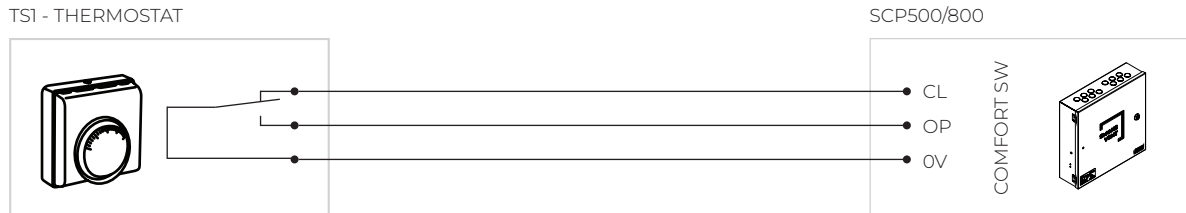

## 24V DC Damper Motor

3-Wire dampers can also be connected as shown below. Ensure correct cable sizes are used to suit the total current drawn by the connected motors. The total current consumed by the connected motors/dampers to the output cannot exceed 5A for SCP500 or 8A for SCP800.

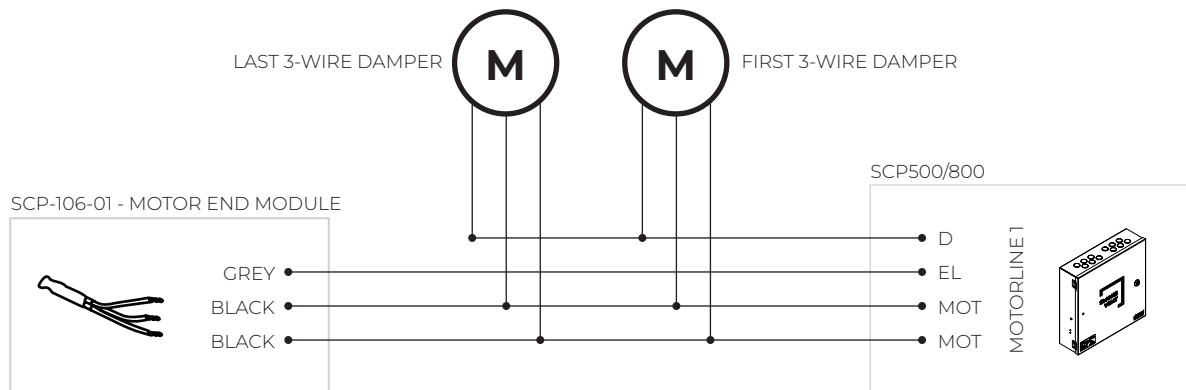

## HMI-SCP - Touchscreen User Interface

A HMI-SCP touchscreen user interface can be connected to the network to provide complete system status. If connected this will become the MASTER panel on the network, all other control panels must be configured as SLAVE panels (dip switch 7 off).

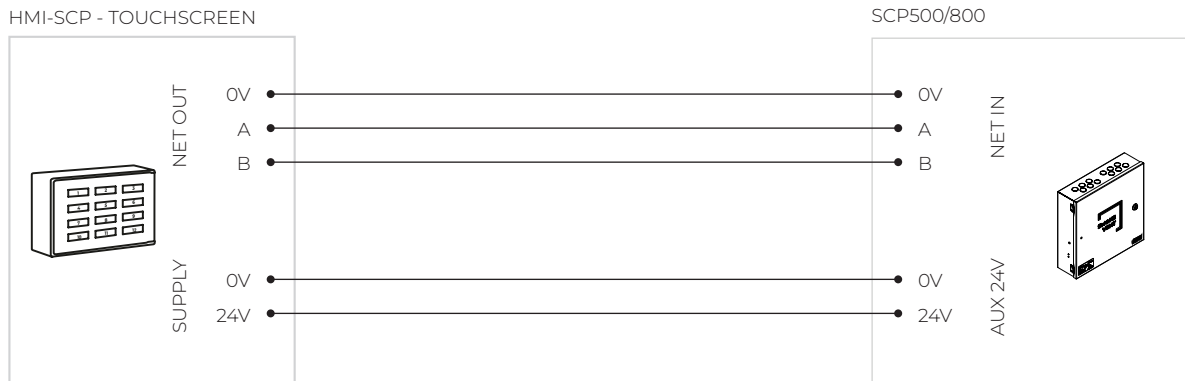

## Auxiliary 24v Supply

A 24v supply is provided on the AUX terminal. This supply is limited to 100mA. This output can be used to supply 24v relays or other 24v indicators when there are custom requirements for example.

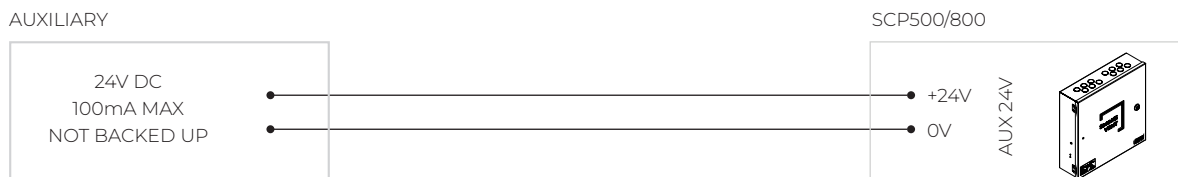

## 12. Networking

### Network Details

- Maximum 31 x control panels can be networked together (30 x if HMI-SCP is connected).
- Only one master per network.
- Assign non-master control panels 1-30 in sequence without missing any numbers - Please refer to pages 12-13 for network address and dip switch configuration.
- Zones cannot use comfort inputs if there are any other zones in fire.
- Comfort inputs are disabled if DIP 10 (network comfort) is set to on - comfort commands come from network.
- If any zone is open for comfort, it will close automatically if there are any other zones in fire.
- Lockout cannot be used if network fire is enabled.
- Locked out zones will close and remain closed until reset.
- Reset from any zone will always reset all other zones on the network.
- Systems with stair roof and shaft roof (using DIP 9 - network fire) will both open with any other zone in fire or if just the stair is in fire.
- Set last zone as master. If system has shaft, set shaft as master. if no shaft but has stairs, set stair as master.
- After reset, comfort signals will be available after approximately 60 seconds.
- Network reset (from call point on other networked control panel(s)).

### Net Err LED

- Network master dip set but network address set to 0.
- Network master cannot communicate with total number of expected remote zones.
- Remote zone cannot communicate with network master.
- Multiple network masters on the same network.
- Network fault led flashing while OK led lit means fault on other network zone (shown with ok lit and amber flashing on call point).

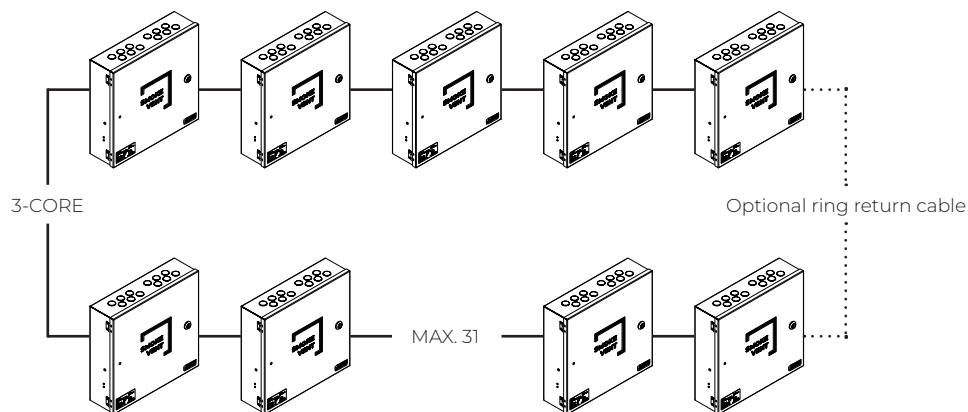

## Network Connections

Several SCP500/800 control panels can be linked together to form a multi-zone system. Connect the control panel network outputs (NET OUT) to the next control panel's network inputs (NET IN), repeat these connections across the network. A maximum of 31 x SCP500/800 control panels can be linked together on the same network.

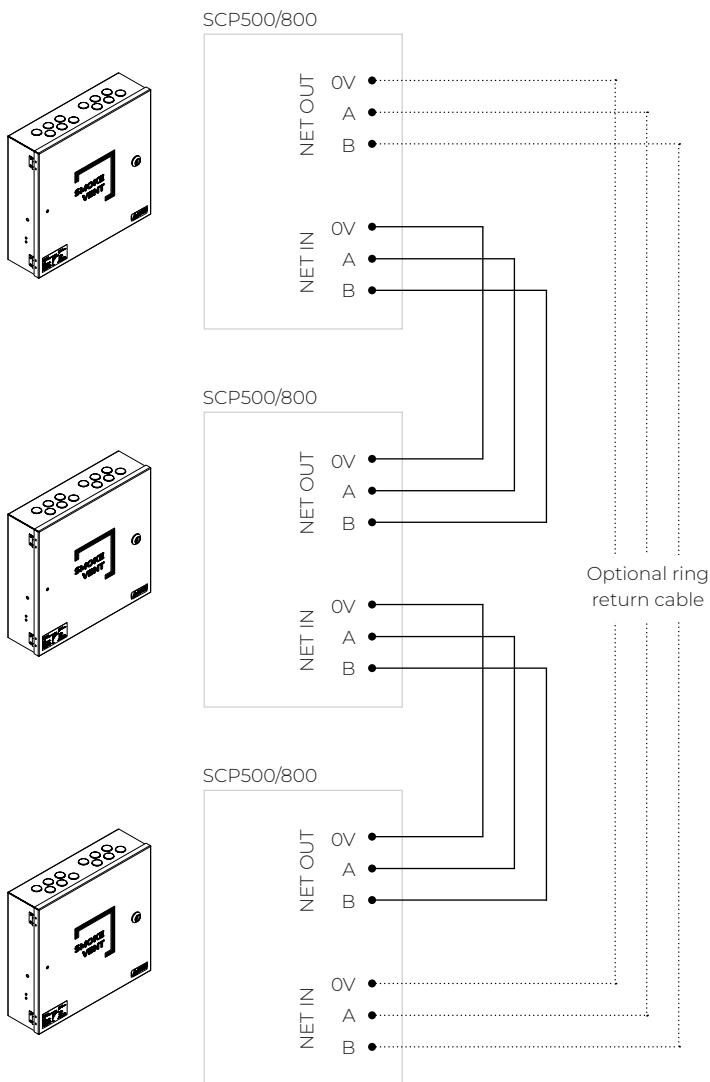

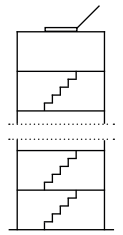

## 13. System Types

### Single-Zone Stairwell System

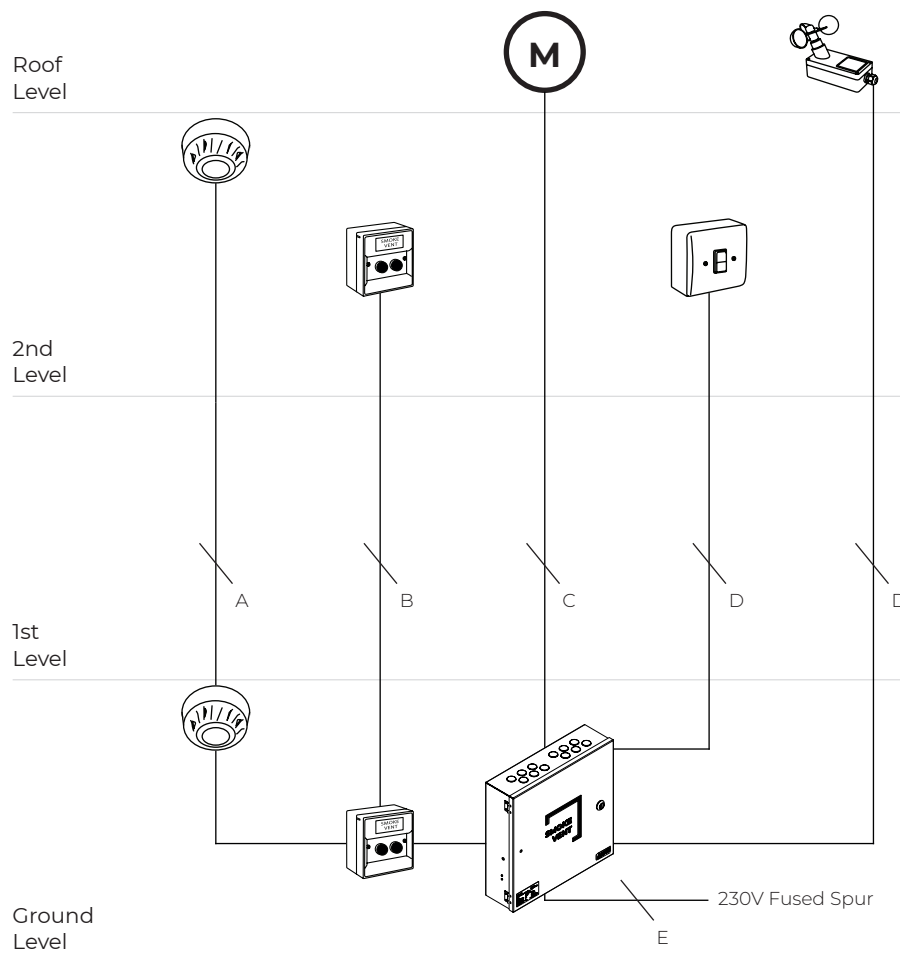

## Cable Sizes

Cable Type	Specification
A	2-core & earth BS 8519 1.5mm
B	3-core & earth BS 8519 1.5mm
C	3-core & earth BS 8519 *Refer to motor cable sizes below
D	3-core & earth 1.5mm
E	2-core & earth 1.5mm

BS 8519 specifies fire-resistant cable performance for life safety and firefighting systems, including smoke ventilation systems. Whilst Category 2 cable may be suitable for some applications, Teal recommends the use of Category 3 cable to provide support for firefighting operations. Note that BS 8519 Category 3 compliance is not automatically achieved by all fire alarm cables, including cables classified as BS 5839-1 'Enhanced' fire-resisting cables, and requires additional testing and certification in accordance with BS 8519.

## Motor Cable Sizes

Recommended cable sizes from control panel to motor(s) depending on total motor consumption.

Motor Current Consumption	3-Wire 0.75mm <sup>2</sup>	3-Wire 1.5mm <sup>2</sup>	5-Wire 1.5mm <sup>2</sup>	3-Wire 2.5mm <sup>2</sup>	5-Wire 2.5mm <sup>2</sup>	3-Wire 4mm <sup>2</sup>
1A	42m	84m	168m	140m	280m	224m
2A	21m	42m	84m	70m	140m	112m
5A	8m	17m	34m	28m	56m	45m
8A	5m	11m	21m	18m	35m	28m

## Network Address Settings

For a single-zone system set the network address to 0.

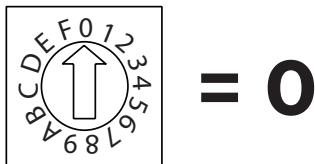

## Dip Switch Settings

Default dip switch settings. Refer to the page 13 for more information.

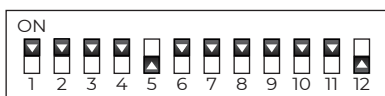

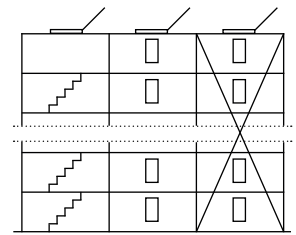

## Multi-Zone - 16-zone max.

Stairwell & Smoke Shaft Lobby System

Smoke Shaft Lobby

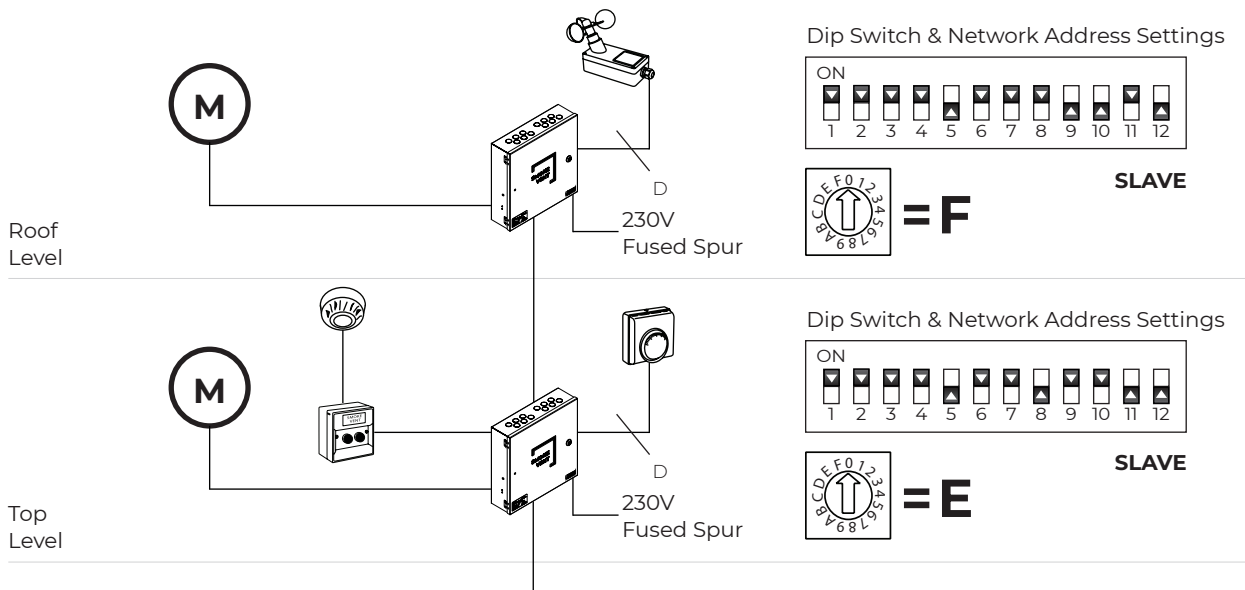

1st 16 Panels = Expansion Dip Switch (3) OFF:

	1 = 1	4 = 4	7 = 7	A = 10	D = 13
	2 = 2	5 = 5	8 = 8	B = 11	E = 14
	3 = 3	6 = 6	9 = 9	C = 12	F = 15

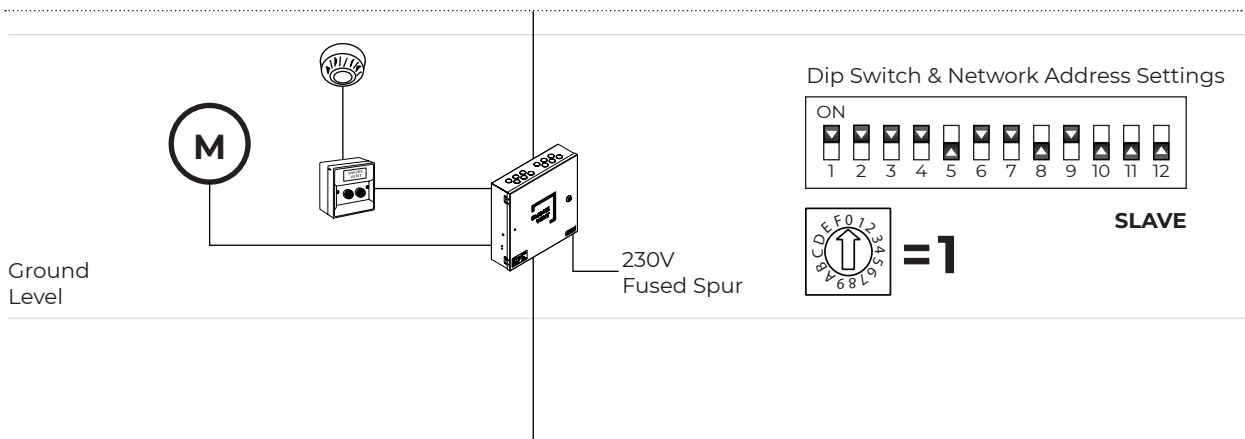

### Cable Sizes

Cable Type	Specification
A	2-core & earth FP200 enhanced 1.5mm
B	3-core & earth FP200 enhanced 1.5mm
C	3-core & earth FP200 enhanced *Refer to motor cable sizes pg.29
D	3-core & earth 1.5mm
E	2-core & earth 1.5mm
F	3-core & earth FP200 enhanced 1.5mm

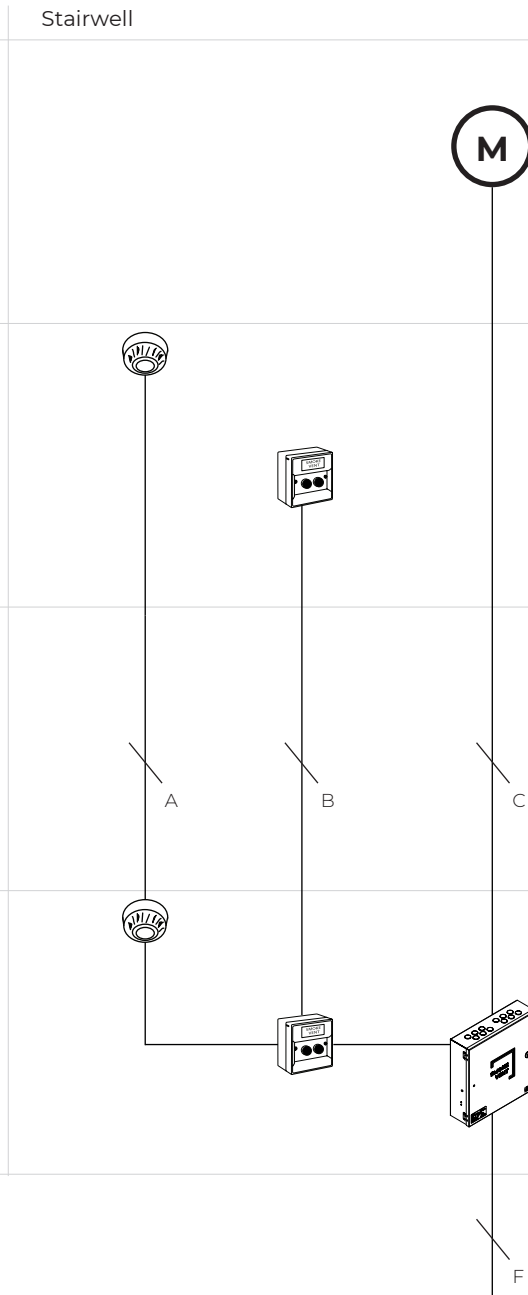

 Only suitable for single lobby (smoke shaft or facade) and stairwell systems. Do not use in buildings with 2 or more lobbies.

#### Dip Switch & Network Address Settings



 There can be only 1 x MASTER panel per network. Assign the master control panel to the number of slave panels i.e. 3 x slave panels, master set to 3 OR 6 x slave panels, master is set to 6.

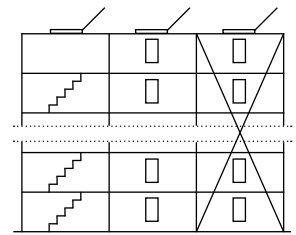

## Multi-Zone - 31-zone max.

Stairwell & Smoke Shaft Lobby System

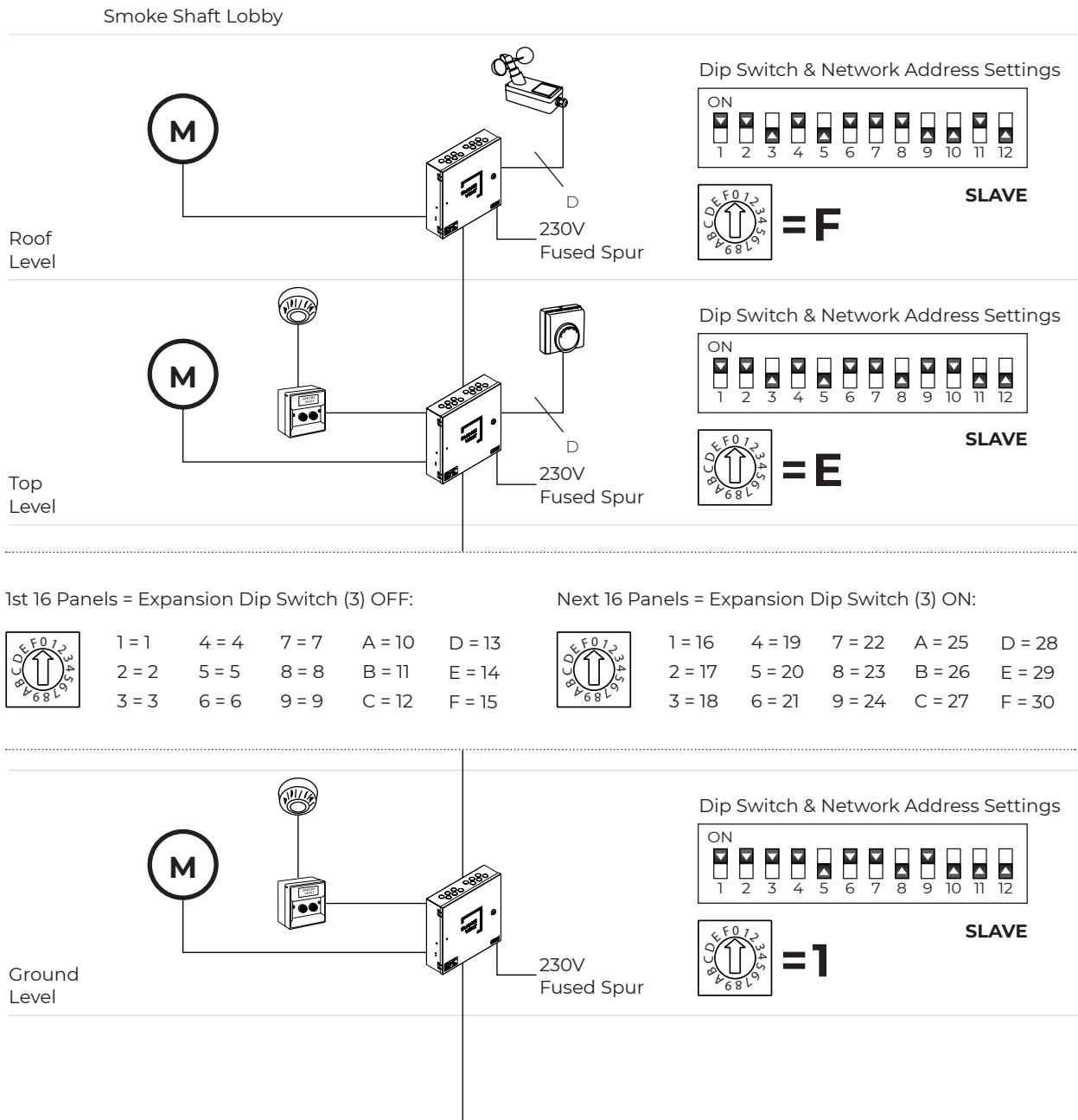

## Cable Sizes

Cable Type	Specification
A	2-core & earth FP200 enhanced 1.5mm
B	3-core & earth FP200 enhanced 1.5mm
C	3-core & earth FP200 enhanced *Refer to motor cable sizes pg.29
D	3-core & earth 1.5mm
E	2-core & earth 1.5mm
F	3-core & earth FP200 enhanced 1.5mm

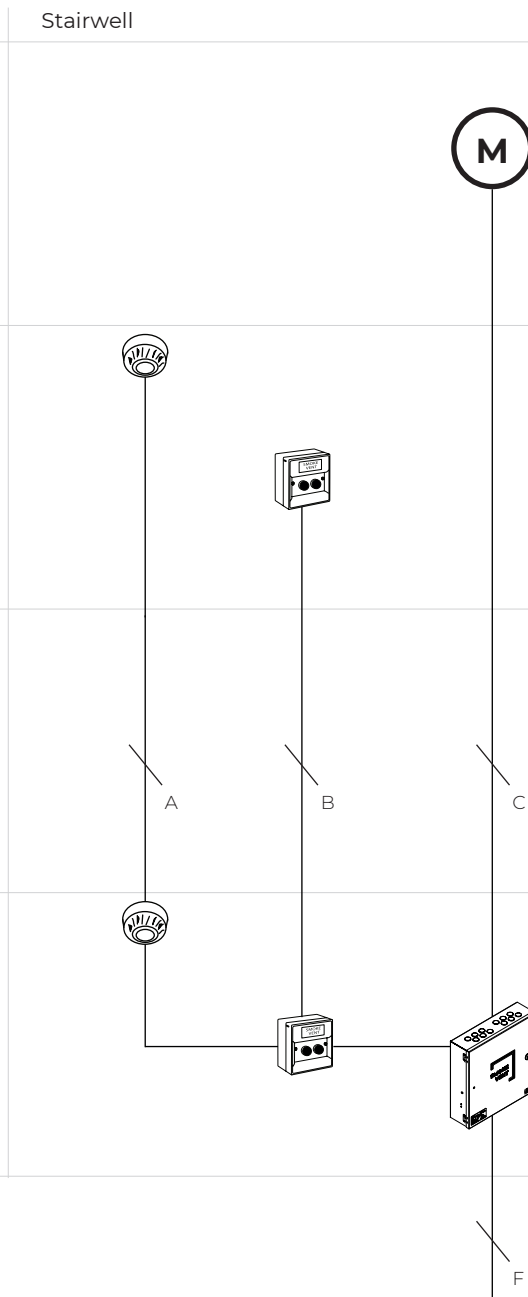

 Only suitable for single lobby (smoke shaft or facade) and stairwell systems. Do not use in buildings with 2 or more lobbies.

### Dip Switch & Network Address Settings



**MASTER**

 There can be only 1 x MASTER panel per network. Assign the master control panel to the number of slave panels i.e. 3 x slave panels, master set to 3 OR 6 x slave panels, master is set to 6.

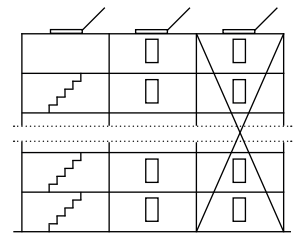

## HMI-SCP Multi-Zone - 30-zone max.

Stairwell & Smoke Shaft Lobby System

Smoke Shaft Lobby

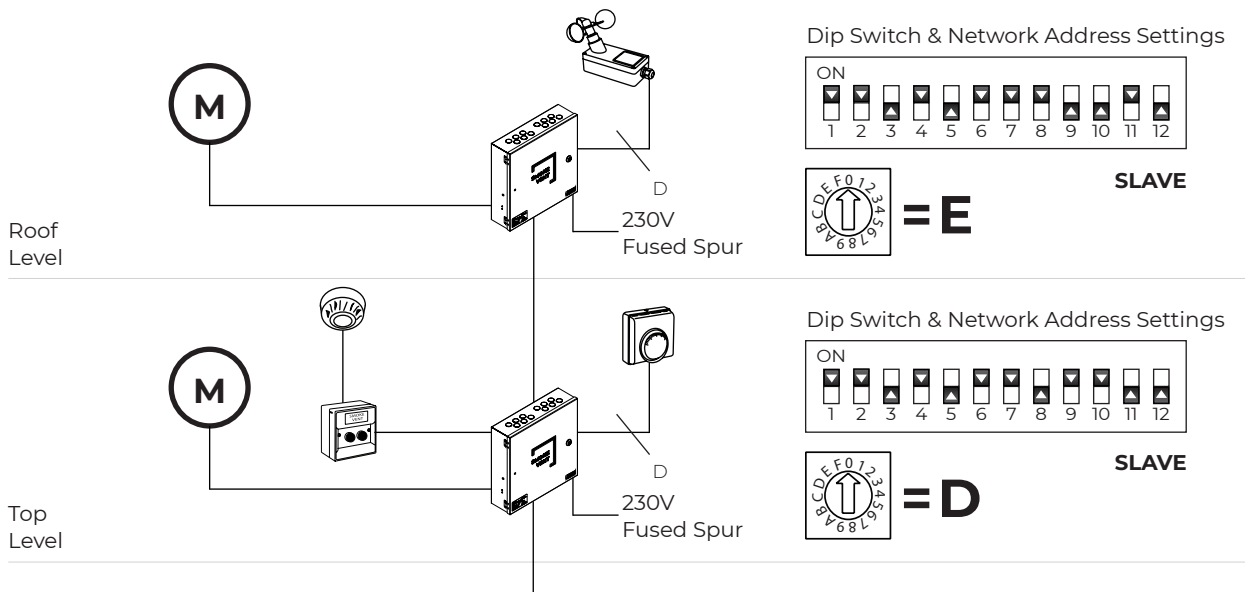

1st 16 Panels = Expansion Dip Switch (3) OFF:



- |       |       |       |        |        |
|-------|-------|-------|--------|--------|
| 1 = 1 | 4 = 4 | 7 = 7 | A = 10 | D = 13 |
| 2 = 2 | 5 = 5 | 8 = 8 | B = 11 | E = 14 |
| 3 = 3 | 6 = 6 | 9 = 9 | C = 12 | F = 15 |

Next 16 Panels = Expansion Dip Switch (3) ON:



- |        |        |        |        |        |
|--------|--------|--------|--------|--------|
| 1 = 16 | 4 = 19 | 7 = 22 | A = 25 | D = 28 |
| 2 = 17 | 5 = 20 | 8 = 23 | B = 26 | E = 29 |
| 3 = 18 | 6 = 21 | 9 = 24 | C = 27 | F = 30 |

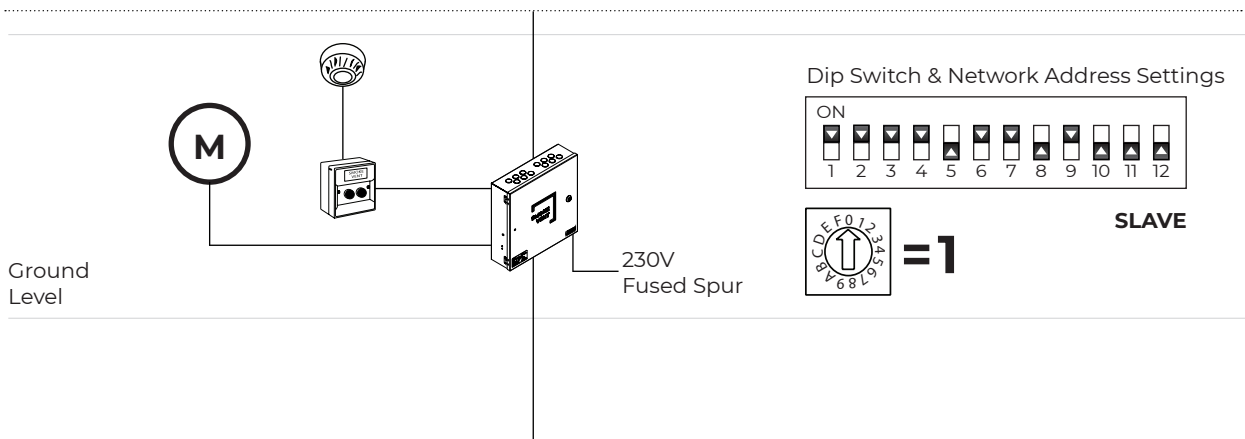

## Cable Sizes

Cable Type	Specification
A	2-core & earth FP200 enhanced 1.5mm
B	3-core & earth FP200 enhanced 1.5mm
C	3-core & earth FP200 enhanced *Refer to motor cable sizes pg.29
D	3-core & earth 1.5mm
E	2-core & earth 1.5mm
F	3-core & earth FP200 enhanced 1.5mm
G	5-core & earth FP200 enhanced 1.5mm

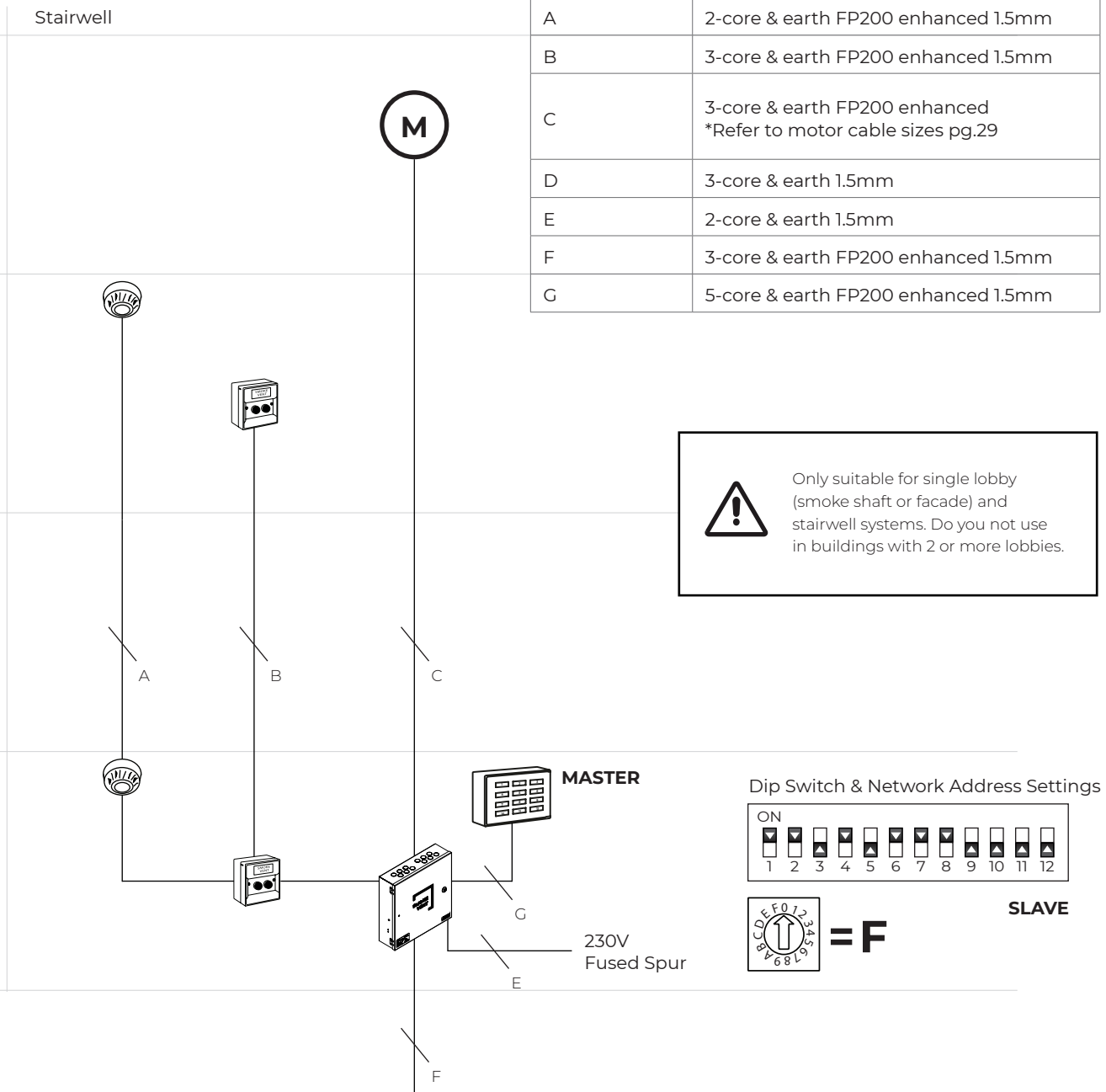

## Cause & Effect - Fire

Showing fire operations with DIP 8 (lockout) set on smoke shaft inlet and lobby zones, and DIP 9 (network fire) set on head of stairwell and head of smoke shaft zones.

Zone	Network Address	Dip Switches	Location	↓	↓	↓	↓	↓
1	1	#8 = ON	Smoke Shaft Inlet	Fire	Locked Out	Locked Out	Locked Out	Locked Out
2	2	#8 = ON	Smoke Shaft Inlet	Locked Out	Fire	Locked Out	Locked Out	Locked Out
3	3	#8 = ON	Smoke Shaft Inlet	Locked Out	Locked Out	Fire	Locked Out	Locked Out
4	4	#8 = ON	Smoke Shaft Inlet	Locked Out	Locked Out	Locked Out	Fire	Locked Out
5	5	#8 = ON	Smoke Shaft Inlet	Locked Out	Locked Out	Locked Out	Locked Out	Fire
6	6	#8 = ON	Smoke Shaft Inlet	Locked Out	Locked Out	Locked Out	Locked Out	Locked Out
7	7	#8 = ON	Smoke Shaft Inlet	Locked Out	Locked Out	Locked Out	Locked Out	Locked Out
8	8	#8 = ON	Smoke Shaft Inlet	Locked Out	Locked Out	Locked Out	Locked Out	Locked Out
9	9	#8 = ON	Smoke Shaft Inlet	Locked Out	Locked Out	Locked Out	Locked Out	Locked Out
10	A	#8 = ON	Smoke Shaft Inlet	Locked Out	Locked Out	Locked Out	Locked Out	Locked Out
11	B	#8 = ON	Smoke Shaft Inlet	Locked Out	Locked Out	Locked Out	Locked Out	Locked Out
12	C	#8 = ON	Smoke Shaft Inlet	Locked Out	Locked Out	Locked Out	Locked Out	Locked Out
13	D	#8 = ON	Smoke Shaft Inlet	Locked Out	Locked Out	Locked Out	Locked Out	Locked Out
14	E	#8 = ON	Smoke Shaft Inlet	Locked Out	Locked Out	Locked Out	Locked Out	Locked Out
15	F	#9 = ON	Head of Smoke Shaft	Fire	Fire	Fire	Fire	Fire
16	F	#7 & 9 = ON <b>MASTER</b>	Head of Stairwell	Fire	Fire	Fire	Fire	Fire

↓	↓	↓	↓	↓	↓	↓	↓	↓	↓	↓
Locked Out	Locked Out	Locked Out	Locked Out	Locked Out	Locked Out	Locked Out	Locked Out	Locked Out	Locked Out	Locked Out
Locked Out	Locked Out	Locked Out	Locked Out	Locked Out	Locked Out	Locked Out	Locked Out	Locked Out	Locked Out	Locked Out
Locked Out	Locked Out	Locked Out	Locked Out	Locked Out	Locked Out	Locked Out	Locked Out	Locked Out	Locked Out	Locked Out
Locked Out	Locked Out	Locked Out	Locked Out	Locked Out	Locked Out	Locked Out	Locked Out	Locked Out	Locked Out	Locked Out
Fire	Locked Out	Locked Out	Locked Out	Locked Out	Locked Out	Locked Out	Locked Out	Locked Out	Locked Out	Locked Out
Locked Out	Fire	Locked Out	Locked Out	Locked Out	Locked Out	Locked Out	Locked Out	Locked Out	Locked Out	Locked Out
Locked Out	Locked Out	Fire	Locked Out	Locked Out	Locked Out	Locked Out	Locked Out	Locked Out	Locked Out	Locked Out
Locked Out	Locked Out	Locked Out	Fire	Locked Out	Locked Out	Locked Out	Locked Out	Locked Out	Locked Out	Locked Out
Locked Out	Locked Out	Locked Out	Locked Out	Fire	Locked Out	Locked Out	Locked Out	Locked Out	Locked Out	Locked Out
Locked Out	Locked Out	Locked Out	Locked Out	Locked Out	Fire	Locked Out	Locked Out	Locked Out	Locked Out	Locked Out
Locked Out	Locked Out	Locked Out	Locked Out	Locked Out	Locked Out	Fire	Locked Out	Locked Out	Locked Out	Locked Out
Locked Out	Locked Out	Locked Out	Locked Out	Locked Out	Locked Out	Locked Out	Fire	Locked Out	Locked Out	Locked Out
Locked Out	Locked Out	Locked Out	Locked Out	Locked Out	Locked Out	Locked Out	Locked Out	Fire	Locked Out	Locked Out
Fire	Fire	Fire	Fire	Fire	Fire	Fire	Fire	Fire	Fire	Fire
Fire	Fire	Fire	Fire	Fire	Fire	Fire	Fire	Fire	Fire	Fire

## Cause & Effect - Comfort

Showing comfort operations with DIP 10 and DIP 11 set on for head of stairwell and head of smoke shaft zones so a smoke shaft can be used for environmental ventilation. Rain sensor connected to head of smoke shaft panel for example.

Zone	Network Address	Dip Switches	Location	↓	↓	↓	↓	↓
1	1	#8 = ON	Smoke Shaft Inlet	Open	No Change	No Change	No Change	No Change
2	2	#8 = ON	Smoke Shaft Inlet	No Change	Open	No Change	No Change	No Change
3	3	#8 = ON	Smoke Shaft Inlet	No Change	No Change	Open	No Change	No Change
4	4	#8 = ON	Smoke Shaft Inlet	No Change	No Change	No Change	Open	No Change
5	5	#8 = ON	Smoke Shaft Inlet	No Change	No Change	No Change	No Change	Open
6	6	#8 = ON	Smoke Shaft Inlet	No Change	No Change	No Change	No Change	No Change
7	7	#8 = ON	Smoke Shaft Inlet	No Change	No Change	No Change	No Change	No Change
8	8	#8 = ON	Smoke Shaft Inlet	No Change	No Change	No Change	No Change	No Change
9	9	#8 = ON	Smoke Shaft Inlet	No Change	No Change	No Change	No Change	No Change
10	A	#8 = ON	Smoke Shaft Inlet	No Change	No Change	No Change	No Change	No Change
11	B	#8 = ON	Smoke Shaft Inlet	No Change	No Change	No Change	No Change	No Change
12	C	#8 = ON	Smoke Shaft Inlet	No Change	No Change	No Change	No Change	No Change
13	D	#8 = ON	Smoke Shaft Inlet	No Change	No Change	No Change	No Change	No Change
14	E	#8 = ON	Smoke Shaft Inlet	No Change	No Change	No Change	No Change	No Change
15	F	#9, 10 & 11 = ON	Head of Smoke Shaft	Open	Open	Open	Open	Open
16	F	#7, 9 & 10 = ON <b>MASTER</b>	Head of Stairwell	Open	Open	Open	Open	Open

↓	↓	↓	↓	↓	↓	↓	↓	↓	↓	↓
No Change	No Change	No Change	No Change	No Change	No Change	No Change	No Change	No Change	Closed	No Change
No Change	No Change	No Change	No Change	No Change	No Change	No Change	No Change	No Change	Closed	No Change
No Change	No Change	No Change	No Change	No Change	No Change	No Change	No Change	No Change	Closed	No Change
No Change	No Change	No Change	No Change	No Change	No Change	No Change	No Change	No Change	Closed	No Change
No Change	No Change	No Change	No Change	No Change	No Change	No Change	No Change	No Change	Closed	No Change
Open	No Change	No Change	No Change	No Change	No Change	No Change	No Change	No Change	Closed	No Change
No Change	Open	No Change	No Change	No Change	No Change	No Change	No Change	No Change	Closed	No Change
No Change	No Change	Open	No Change	No Change	No Change	No Change	No Change	No Change	Closed	No Change
No Change	No Change	No Change	Open	No Change	No Change	No Change	No Change	No Change	Closed	No Change
No Change	No Change	No Change	No Change	Open	No Change	No Change	No Change	No Change	Closed	No Change
No Change	No Change	No Change	No Change	No Change	Open	No Change	No Change	No Change	Closed	No Change
No Change	No Change	No Change	No Change	No Change	No Change	Open	No Change	No Change	Closed	No Change
No Change	No Change	No Change	No Change	No Change	No Change	No Change	Open	No Change	Closed	No Change
No Change	No Change	No Change	No Change	No Change	No Change	No Change	No Change	Open	Closed	No Change
Open	Open	Open	Open	Open	Open	Open	Open	Open	Closed	Closed
Open	Open	Open	Open	Open	Open	Open	Open	Open	Closed	Rain

## 14. Troubleshooting

Problem	Cause	Rectification
AOV closes when in fire and opens when close/reset.	Motor connections are reversed.	Swap the cables over in the MOT terminals of MOTOR LINE 1 or at the motor.
AOV closes when open button of the comfort switch is pressed or the thermostat is turned down, but the AOV opens on fire.	Open and close inputs are reversed on the COMFORT input or in the switch/thermostat.	Swap the cables over in the OP and CL terminals of COMFORT SW.
SD ERR indicator LED illuminated but smoke detector is connected.	10k end of line missing or smoke detector head removed.	Fit 10k end of line resistor as section 9 or fit smoke detector head to base.
BG ERR indicator LED illuminated but call points are connected.	For 6-wire breakglass 10k end of line resistor is missing.  For 3-wire breakglass if DIP switch 12 is on, the connections may be incorrect. Or the BG3-PRO has not been configured.	Fit the 10k end of line resistor, or install end of line jumper in last break glass  Check connections. On each BG3-PRO are correct as section 9. Discovery must be performed on each BG3-PRO, see section 10.
MOT ERR indicator LED is illuminated.	End of line is missing or FUSE MOT has blown.	Check the motor end of line is connected correctly as section 9. If the end of line is correct, check the FUSE MOT is intact. If the fuse was blown, check for short-circuit on motor cabling and replace.
OVERLOAD indicator LED is illuminated.	Short circuit on 6-WIRE BREAKGLASS, 3-WIRE BGS, SMOKE DET, AUX 24V, RAIN SENS.cabling.  Excessive load on AUX 24V.  Surge by rain sensor connection.	Check cabling. If the problem is on the call points or smoke detector circuits, the BG ERR or SD ERR indicator LEDs will also be illuminated.  Ensure <100mA load on AUX 24v output.  Connecting the rain sensor while the SCP500/800 is powered up can cause a surge on the output.  After resolving the OVERLOAD problem, press the on-board RESET button to re-establish power to the affected circuit.
PSU ERR indicator LED is illuminated.	Mains power is not available.  FUSE MAINS 2A blown.	Check mains is connected correctly and switched on.  Check for any faults on the mains connections then replace the fuse and restore mains power.
BAT ERR indicator LED illuminated.	Batteries disconnected.  Batteries depleted.  FUSE BAT blown.	Connect batteries as section 9.  Check the battery voltage and replace if necessary.  Check battery leads are not damaged and replace the fuse.

## 15. Commissioning

After installation and connected peripherals and mains supply have been correctly terminated and checked;

### SCP Control Panel

- Check the DIP switches are set to operate the SCP500/800 as required.
- Switch on the mains supply and the SCP500/800 will initially power up. BAT ERR indicator LED will be illuminated until the batteries are connected.
- Connect the batteries as Section 11.
- The OK indicator LED should now illuminate. If not, check for any yellow fault indicators and refer to troubleshooting Section 14.
- Test the connected AOV operates in the correct direction when the fire button is pressed. Ensure it is safe to do so before operating the AOV.
- Press the internal fire button, the SCP500/800 will enter fire condition and the red FIRE indicator LED will illuminate.
- Check the AOV is opening/has opened.
- If the AOV is closed, swap the connections of the two cables in the MOT terminals of MOTOR LINE 1.

### BG3-PRO Pairing

- Ensure all connections are made with SCP500/800 powered off.
- Set dip switch 12 in the SCP500/800 to ON.
- Turn mains supply on and connect batteries.
- The BG3-PRO will beep and the LED's will start flashing to confirm pairing mode.
- Press the 'CLOSE/RESET' button on the BG3-PRO.
- The BG3-PRO will beep and the LED's will stop flashing to confirming pairing is complete.
- If two BG3-PRO are connected you must ensure the 'CLOSE/RESET' button on the second BG3-PRO is pressed within 5 minutes.

### BG3-PRO Unpairing

- Press and hold the 'FIRE' and 'RESET' buttons inside the SCP500/800 for 10 seconds then release.
- Press the SCP500/800 'RESET' button again.
- Set dip switch 12 in the SCP500/800 to OFF.
- Press the SCP500/800 'RESET' button again.

### Call Points

- Check the green OK indicator LED is illuminated.
- Press the red FIRE button, and check the red LED indicator illuminates.
- Press the black reset/close button and check the red LED indicator turns off.

### Smoke Detectors

- Spray with synthetic smoke detector tester aerosol and check the AOV activates open. Red indicator LEDs will illuminate on the SCP500/800 internally and on each connected call point.
- Press the reset/close black button in the call point to clear the fire condition. Note: the smoke detector may re-activate if smoke spray is still in the chamber of the smoke detector, in this case, wait a minute or so and press the reset/close black button again. The AOV should now close.

### Comfort Commands

- If a comfort switch or a thermostat is installed, check the operation is as expected.
- If a rain sensor is installed, open the AOV using the comfort switches/thermostat. For a thermostat turn the temperature dial down all the way to open the AOV. Wet the rain sensor slightly to trigger a rain signal. The blue RAIN indicator LED will illuminate in the control panel and the AOV will close. Rain sensors usually latch the rain signal for a few minutes. When the rain signal has cleared, the comfort switches will be operable again. If a thermostat is connected and calling for cooling, the AOV will re-open. Note: if the SCP500/800 is in fire conditions the rain sensor will not close the AOV.

## 16. Log Book

<b>THIS LOG BOOK RECORDS THE TESTING OF THE SMOKE CONTROL SYSTEM AT:</b>			
NAME OF PROPERTY:			
ADDRESS:			
<b>THE PERSON WITH MANAGEMENT RESPONSIBILITY FOR THE SYSTEM IS:</b>			
NAME:			
ADDRESS:			
CONTACT DETAILS:			
<b>THE COMPANY WHO CARRIES OUT SERVICING &amp; MAINTENANCE ON THIS SYSTEM IS:</b>			
NAME:			
ADDRESS:			
CONTACT DETAILS:			
<b>THE SYSTEM WAS INSTALLED BY:</b>			
NAME:			
CONTACT DETAILS:			
MONTH/YEAR:			
<b>TESTING THE AOV/SMOKE CONTROL SYSTEM:</b>			
<b>WEEKLY TEST</b>	DEVICE TESTED & LOCATION		
		YES	NO
	THE SYSTEM ACTIVATED CORRECTLY & ALL ACTUATORS INSPECTED		
	THE SYSTEM RESET CORRECTLY & ALL ACTUATORS RETURNED TO CLOSE		
	THE CONTROL PANEL INDICATES HEALTHY STATUS		
	ANY FAULTS FOUND HAVE BEEN RECORDED IN THE FAULTS SECTION & REPORTED TO:		
BY:		DATE:	
		TIME:	

## 17. Support

### Technical Support

Tel 01242 622959  
Email [technical@tealproducts.co.uk](mailto:technical@tealproducts.co.uk)



**HOW TO  
Video Guides**



**Product Training**



**Product Information**

