

FTA 600GF

FOLDING ARM ACTUATOR

OPENING STROKE SIZES

93° (programmable)

PUSH FORCE

600 N

VOLTAGE

24V DC (+/- 10%)



DESCRIPTION

The FTA 600GF folding arm actuator has been developed for installation on side-hung outward opening windows or doors. Supplied with potential-free contact used for control of an electric door-opener or a bolt lock. Folding arm drives can be used in SHEV systems and as well as for natural ventilation via automated windows, mainly in façades. Opening stroke is programmable (in factory) - 0-93°. Fixing brackets sold separately.

WINDOW TYPES

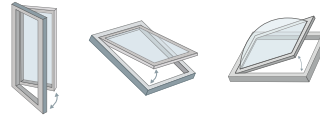

APPLICATION



COLOURS

- Silver Anodised
- ⊗ Custom RAL colour

CERTIFICATION



TECHNICAL DATA

Voltage	24V DC (+/- 10%)
Push Force	600 N
Pull Force	600 N
Opening Stroke	93° (programmable)
Opening Speed	2,0°/sec
Current Consumption	1.4 A
Operating Conditions	-5°C - +75°C
Switch-on Duration	30 % (ON: 3 min. / OFF: 7 min.)
Colour	Silver Anodised or custom RAL colour
IP Rating	IP 32
Life Span	10,000 opening and closing movements
Delivery Includes	1 x Actuator (fixing brackets sold separately)
Flex Length	3 m
Cable Dimensions	2-Core (plus 3 commincation wires)
Min. window width	> 600 mm (Side-Hung)
Max. window width	< 1200 mm (Side-Hung)
Synchronisation	Yes (programmable)

ACCESSORIES

FTA600DF524172 - Inward Opening Bracket Set

PART CODES

FTA600GF - FTA 600GF Actuator 24 V 90° Silver

FTA600GF-2 - FTA 600GF Actuator (synchronised) 24 V 90° Silver

DIMENSIONS

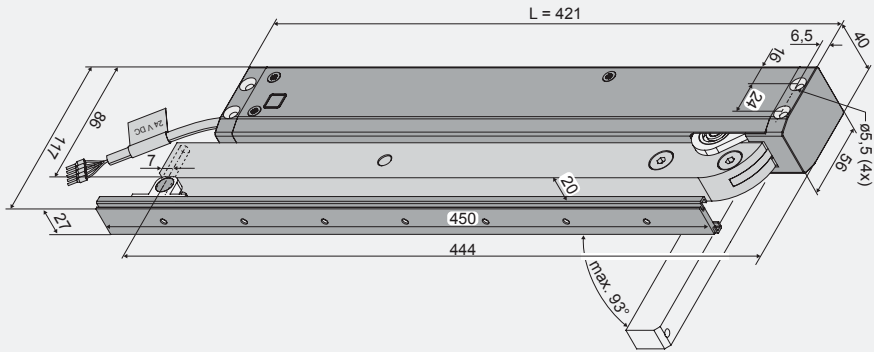

CONTROLS



WSC 204
AOV Control Unit



WSK 320
Override Switch



SSR-D
Smoke Sensor



WSC 310
AOV Control Unit

BRACKET
TYPES

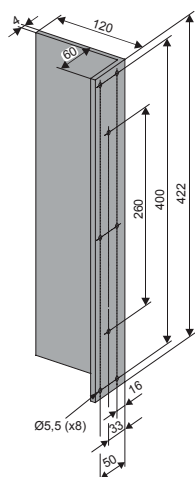

FA600GF-524173